

For information about other American International automotive accessories visit our website at:

<http://www.aius.net>

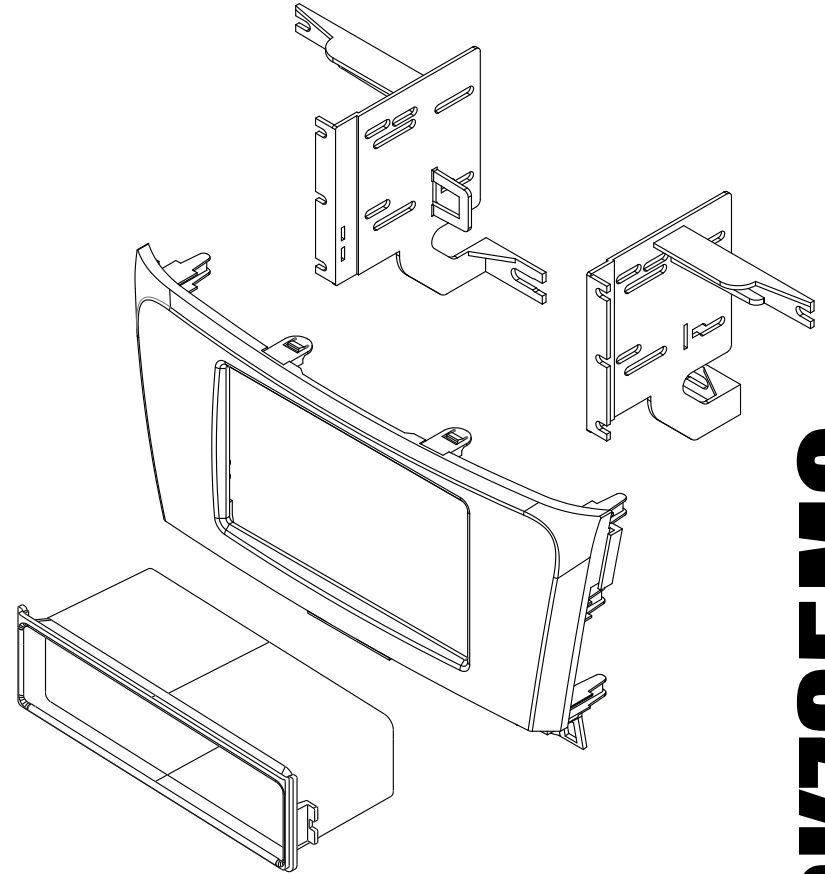

**American International**  
Car Stereo Installation Kits & Accessories



**NDK735MG Mounting Kit**



**American International**

**WWW.AIUS.NET**

2500 East Francis Street Ontario, CA 91761, U.S.A.  
USA Sales (800) 336-6500

**CUSTOMER HELP LINE**  
USA 800-323-4329

iNDK735

**VEHICLE APPLICATIONS**

**NISSAN**  
2014-15 ROGUE

## DASH DISASSEMBLY

1. Using a soft tool unsnap and remove the panel located on the far right passenger dash to the right of the air vent.
2. Remove (1) Phillip screw from passenger side air vent, unsnap and remove
3. Starting from the passenger side using a soft tool unsnap and remove the center dash trim located above the glove box to the radio. You will need to unhook once at radio.
4. Using a soft tool unsnap and remove the climate control panel.
5. Using a soft tool unsnap and remove the panel located on the driver side of the radio(some models may include a push to start button)
6. From the OEM radio brackets remove (4) Phillips screws. Remove Radio. Unplug all harnesses and antenna connections.

## KIT ASSEMBLY INSTRUCTIONS

### Single ISO Mount Applications

1. Insert pocket into lower section of the NDK735MG brackets
2. Install brackets to rear of main frame using the (6) screws provided.
3. Insert ISO mountable radio between ISO mount brackets and loosely attach to sides of radio using screws provided with radio when possible, or screws supplied with kit.
4. Using the main frame of the NDK735MG as a guide, slide radio forward or backward for desired look and then tighten screws to the radio.

**NOTE:** Attach a rear support bracket to the rear of the new radio and adjust as necessary to support the weight of the radio. Suggested.

Fig A

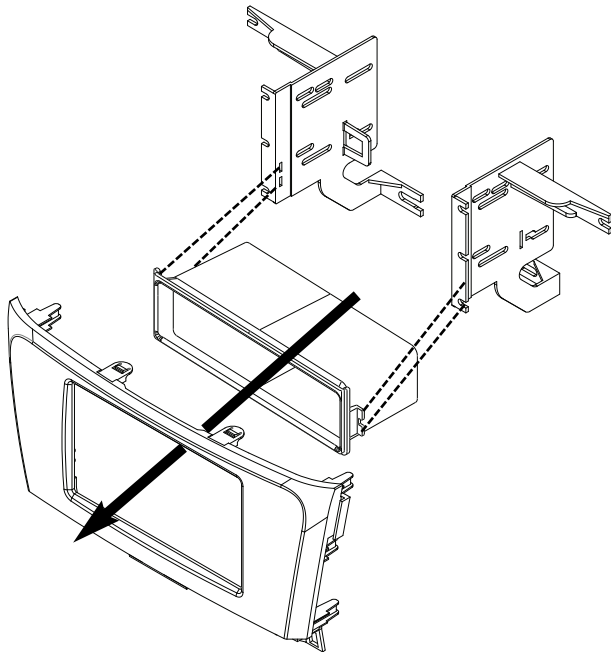

### Double DIN Mount Applications

**See Fig B for bracket tab removal.**

1. Install brackets to rear of main frame using the (6) screws provided.
2. Insert ISO mountable radio between ISO mount brackets and loosely attach to sides of radio using screws provided with radio when possible, or screws supplied with kit.
3. Using the main frame of the NDK735MG as a guide, slide radio forward or backward for desired look and then tighten screws to the radio.

**NOTE:** Attach a rear support bracket to the rear of the new radio and adjust as necessary to support the weight of the radio. Suggested.

Fig B

