

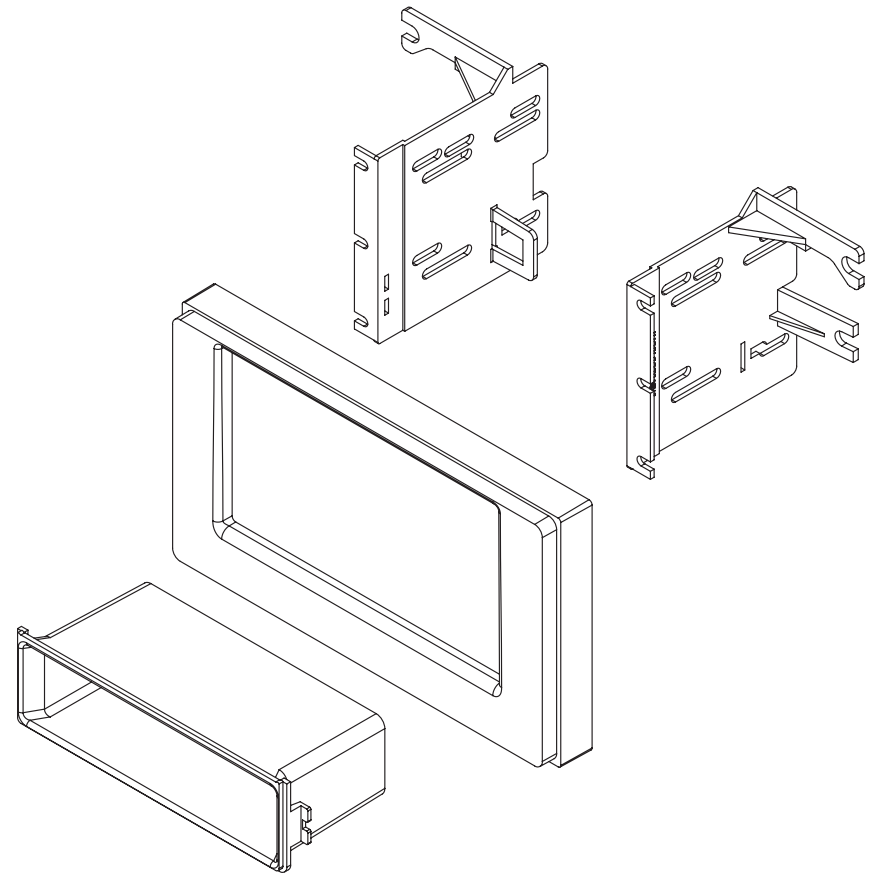

**American
International**
Car Stereo Installation Kits & Accessories



TOYK952GB Mounting Kit



www.aampglobal.com www.aius.net

2500 East Francis Street Ontario, CA 91761, U.S.A.

Sales: (800) 477-2267

Intl: (727) 572-9255

Support: 888-228-5560

iTOYK952GB

VEHICLE APPLICATION

Toyota

2017 CORROLLA

DASH DISASSEMBLY INSTRUCTIONS

1. Using a soft tool Gently unsnap and remove dash trim bezel, that includes the hazard button and airbag light and surrounds the radio. Careful to un-tuck the very bottom corner from behind the factory dash. Unplug all harnesses
2. From the OEM radio brackets remove (4) 10mm bolts. Remove Radio. Unplug all harnesses and antenna connections.

KIT ASSEMBLY INSTRUCTIONS

Single ISO Mount Application

1. Insert pocket into lower section of the brackets and snap into rear pocket support tabs.
2. Install brackets to rear of main frame using the (6) screws provided.
3. Insert ISO mountable radio between ISO mount brackets and loosely attach to sides of radio using screws provided with radio when possible, or screws supplied with kit.
4. Using the main frame of the as a guide, slide radio forward or backward for desired look and then tighten screws to the radio.

Note: Attach a rear support bracket to the rear of the new radio and adjust as necessary to support the weight of the radio. Suggested

Figure A

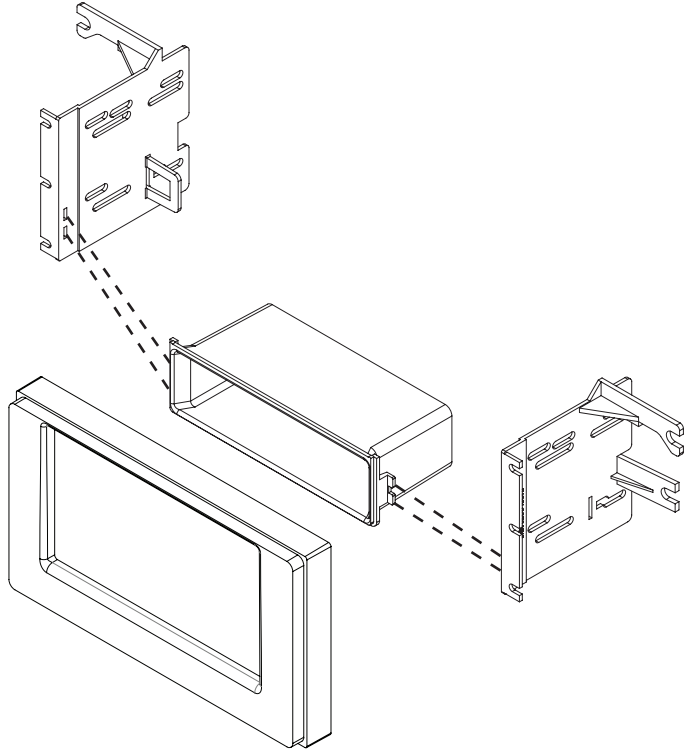

DOUBLE DIN INSTALLATION INSTRUCTIONS

Double DIN ISO Mount Application

See Fig B for bracket tab removal.

1. Install brackets to rear of main frame using the (6) screws provided.
2. Insert ISO mountable radio between ISO mount brackets and loosely attach to sides of radio using screws provided with radio when possible, or screws supplied with kit.
3. Using the main frame of the as a guide, slide radio forward or backward for desired look and then tighten screws to the radio.

Note: Attach a rear support bracket to the rear of the new radio and adjust as necessary to support the weight of the radio. Suggested.

Figure B

