

DASH DISASSEMBLY INSTRUCTIONS

1. Tilt the steering wheel to its lowest position.
2. Engage the parking brake.
3. Insert the ignition key into the ignition switch, and then turn the ignition switch to the ON position. Do not start the engine! (Not required for manual shift vehicles).
4. Depress the brake pedal and adjust the shift lever to the lowest gear position (not required for manual shift vehicles).
5. Carefully unclip the radio / climate control trim bezel by pulling it forward, (towards yourself) paying attention not to damage the hazard button, then disconnect all wire harnesses attached to the rear of the trim bezel and lift the radio / climate control trim bezel upward to remove it from the dashboard.
6. Depress the retaining clips securing the radio to the sub-dash and then pull the radio forward, unplug the harness(s) and antenna lead and remove radio.

DASH PREPARATION

1. Snap the GMK343 main frame into the radio opening in the dash panel.
2. Any areas of plastic from the OEM panel exposed in the GMK343 opening need to be marked-out.
3. Gently remove the GMK343 main frame & carefully remove the areas needed. Snap GMK343 back into radio opening.

NOTE: The Sub Dash May need to be modified to fit the radio chassis

The Subdash May need to be modified to fit the radio chassis

SINGLE ISO MOUNT APPLICATION

1. Insert ISO mountable radio between ISO mount brackets and attach to sides of radio using screws provided with radio when possible, or screws supplied with kit.
2. Plug all necessary harnesses and antenna connections to the radio and slide into the sub dash, until locked into place.
3. Test fit the GMK343 main frame with factory panel by making sure the main frame aligns correctly with the radio and does not leave any gaps when installed.

Suggested...Attach a rear support bracket to the rear of the new radio and adjust as necessary to support the weight of the radio.



**American
International**
Car Stereo Installation Kits & Accessories

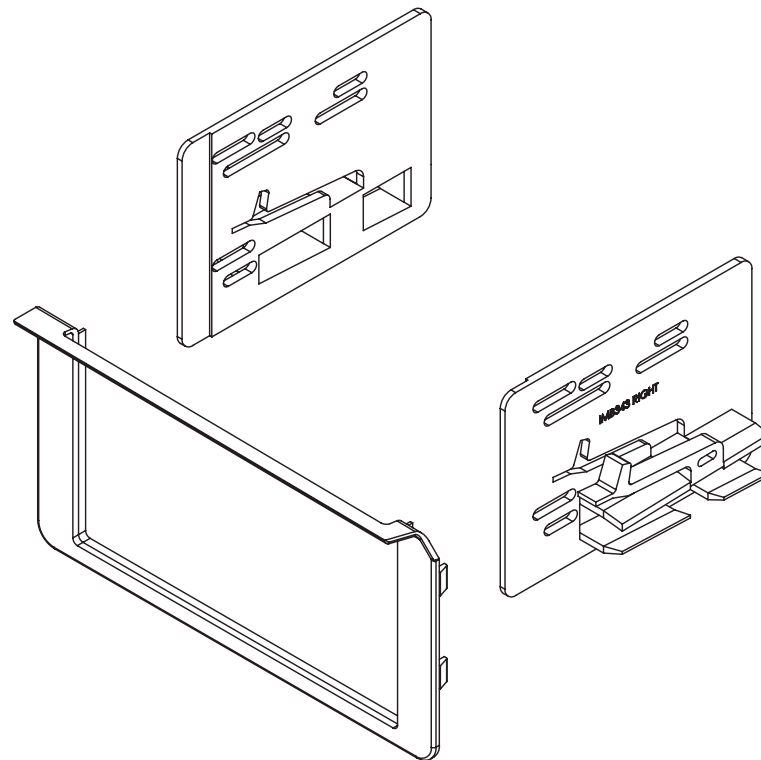

GMK343 Mounting Kit

For Models with separate CD,CASS
or Pocket located under Climate Controls

VEHICLE APPLICATION

CADILLAC

1999-00 ESCALADE

CHEVROLET

1995-02 SILVERADO (Select Models)

1995-99 SUBURBAN

1995-99 TAHOE

GMC

1995-02 SIERRA (Select Models)

1995-99 SUBURBAN

1995-99 YUKON



www.aampglobal.com www.aius.net

2500 East Francis Street Ontario, CA 91761, U.S.A.

Sales: (800) 477-2267

Intl: (727) 572-9255

Support: 888-228-5560