

For information about other American International automotive accessories visit our website at:

<http://www.aius.net>



American International

Car Stereo Installation Kits & Accessories

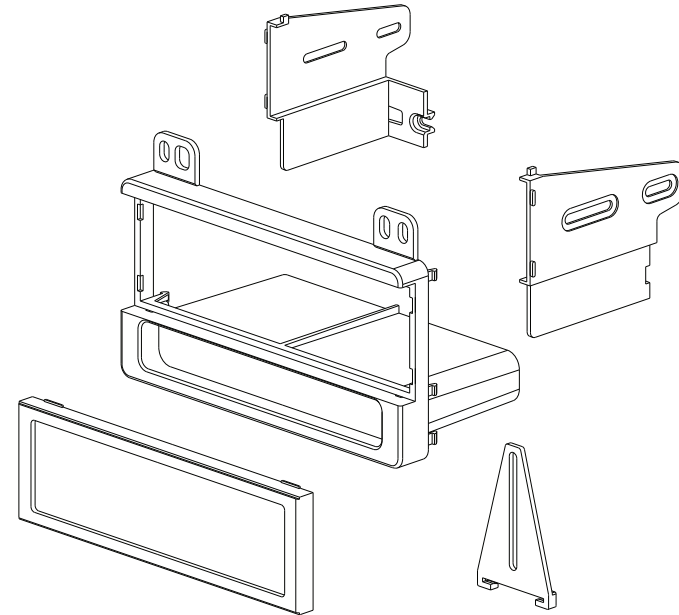

FMK550 Mounting Kit



American International

WWW.AIUS.NET

2500 East Francis Street Ontario, CA 91761, U.S.A.

USA Sales (800) 336-6500

Canada Sales (888) 922-3006

CUSTOMER HELP LINE

USA 800-323-4329 • Canada 800-245-8777

iFMK550

VEHICLE APPLICATIONS

Ford

1995-10 CROWN VICTORIA
1997-08 ECONOLINE VAN (Club Wagon)
2001-07 ESCAPE
2000-05 EXCURSION
1998-06 EXPEDITION (Non Navigation)
1995-05 EXPLORER
2000-06 EXPLORER Sport Trac
1999-04 F-SERIES TRUCKS
2004 F-150 (Heritage Only)
2001-04 MUSTANG
1995-11 RANGER
1999-03 WINDSTAR

Ford Commercial Vehicles

1999-08 E-150
1997-08 E-250
1999-08 E-350
1999-08 E-450
2002-04 F-250
2002-04 F-350
2002-04 F-450

Ford Commercial Vehicles Cont.

2002-04 F-550
2002-07 F-650
2003-04 F-750

Lincoln

2003-05 AVIATOR
2001-02 BLACKWOOD
1995-97 CONTINENTAL
1995-98 MARK VIII
1999-06 NAVIGATOR
1995-02 TOWN CAR

Mazda

1995-10 B-SERIES P/U's

Mercury

2001-02 COUGAR (flat face radios only)
1995-10 GRAND MARQUIS
1997-05 MOUNTAINEER
2003-04 MARAUDER
2005-07 MARINER

NOTES:

1. Carefully pry the top center Vent Panel assembly upward and remove.
2. Remove the (2) 9/32 screws securing the top of the radio trim bezel.
3. Carefully pry the lower sides of the radio trim bezel slightly forward to release and remove the radio trim bezel.
4. Carefully pry the clock/vent assembly below the radio forward, disconnect the harness and remove clock/vent assembly.
5. Remove the (2) 9/32 screws securing the radio to the sub-dash and save metal bar for reinstallation.
6. Carefully pull radio forward, disconnect the wire harnesses and antenna lead and remove radio.

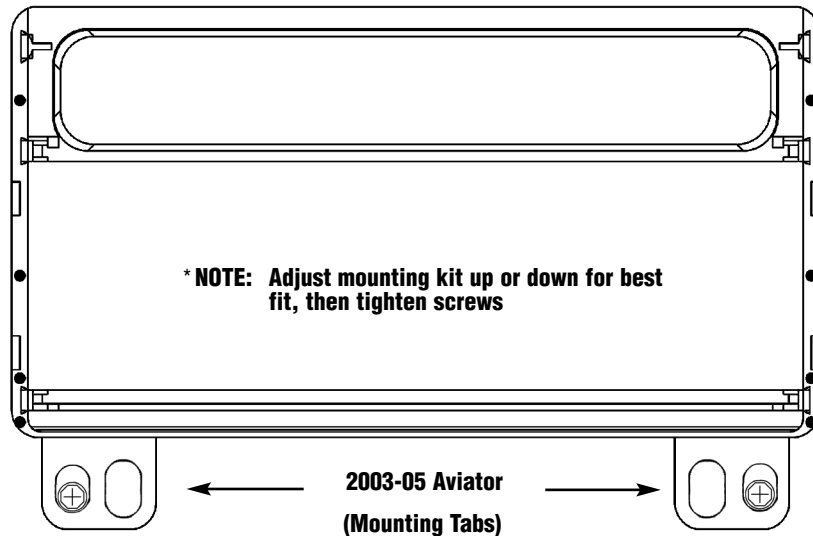

NOTES:

1. Pocket must be on top.
2. You must use the factory style rear support bracket (included).
3. Attach a backstrap from the back of the pocket to the backstrap hole on your radio.

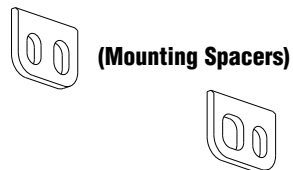

DIN MOUNT ASSEMBLY INSTRUCTIONS

NOTE: Kit must be mounted in dash prior to bending tabs on sleeve

1. Insert DIN sleeve from your new radio into the radio opening of the installation kit as shown in Fig. A.
2. Depress the tabs from inside the sleeves opening upward, outward, and downward to secure the installation kit to the sub-dash.

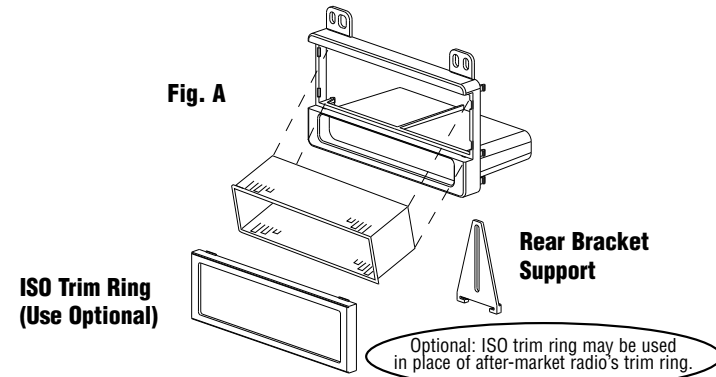

ISO MOUNT ASSEMBLY INSTRUCTIONS

1. Attach left and right mounting brackets to rear of kit as shown in Fig. B and secure to back of pocket using screws provided with kit.
2. Insert ISO mountable radio between ISO mount brackets and loosely attach to sides of radio using screws provided with radio when possible or screws supplied with kit.
3. Attach ISO trim ring to face of kit.
4. Slide radio forward or backward for desired look and tighten screws.

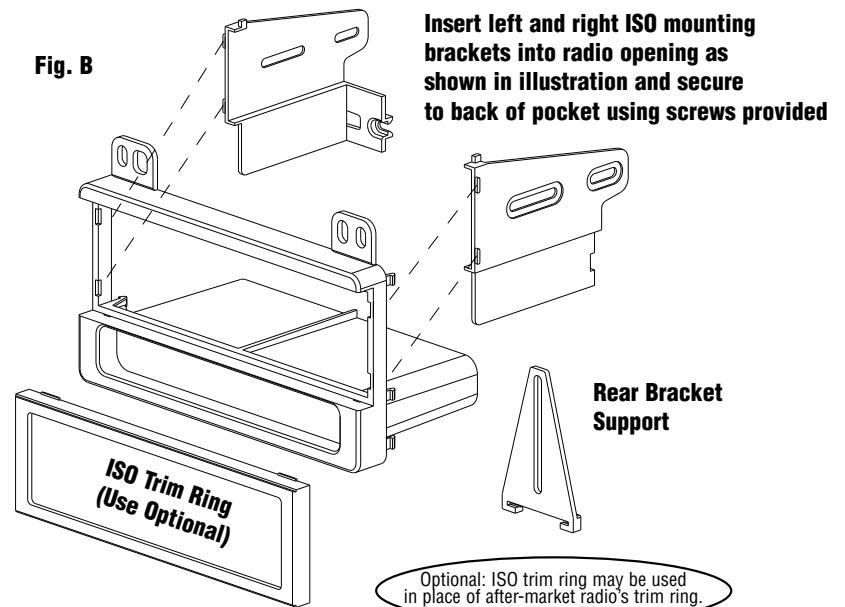

1995-10 Ford Crown Vic
1995-97 Lincoln Continental
1995-98 Lincoln Mark VIII
1995-02 Lincoln Towncar
1995-10 Mercury Grand Marquis
2003-07 Mercury Marauder

NOTES:

1. Pocket must be on top for all vehicle applications.
2. You cannot ISO mount on these applications.
3. You must use the Din mounting sleeves on these applications.
4. Remove the Mustang mounting tabs for these applications.

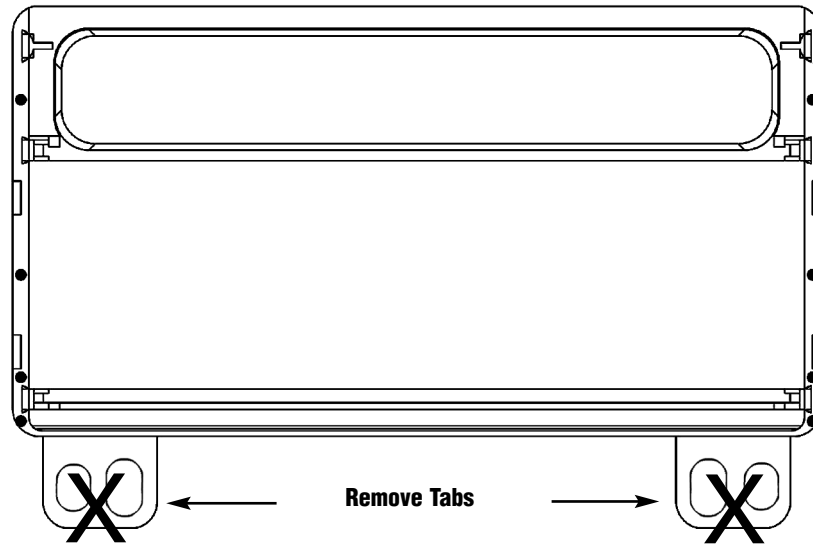

Spacer Nubs
 * See Notes on Page 1

2001-02 Mercury/Cougar

NOTES:

1. This kit only fits Cougar vehicles with a flat face Ford radio, not the curved type (i.e. Ford Focus style).
2. Remove the Mustang mounting tabs for this application.

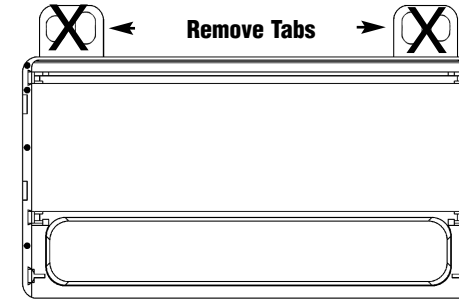

Spacer Nubs
 See Notes on Page 1

1995-01 Explorer (all models)
1997-01 Mountaineer

NOTES:

1. Pocket can be mounted on the top or the bottom.
2. Break off the top right locking tab of the kit. (As shown in Fig. A & B)
3. These vehicles can only be ISO mounted if the pocket is on top.
4. Remove the Mustang mounting tabs for these applications.

FIG A

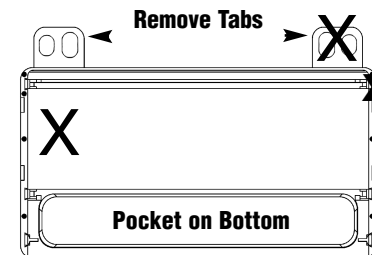
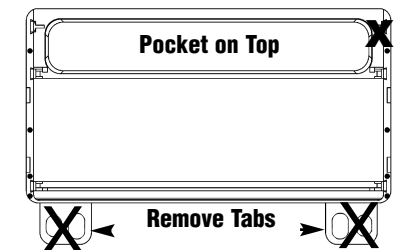

FIG B



See Notes on Page 1

NOTE: See page 4 for 2002-05 Explorer/Mountaineer instructions.

1998-02 Ford Expedition
1997-02 Lincoln Navigator

NOTES:

1. This kit may be mounted in vehicle dash with pocket on top or bottom.
2. You may have to remove the factory rear support bracket, or modify the top of the subdash to allow for the radio or pocket to fit properly.
3. Remove the Mustang mounting tabs for these applications.

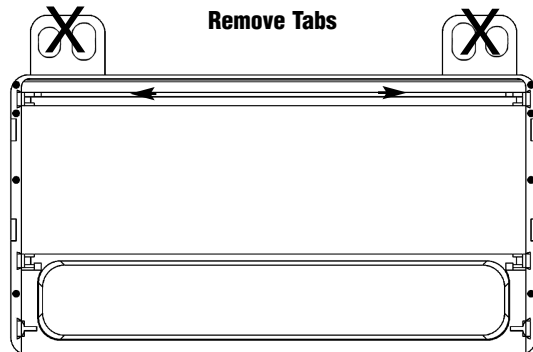

Spacer Nubs
*See Notes
on Page 1

2001-07 Ford Escape
2005-07 Mercury Mariner

NOTES:

1. Pocket can be on top or bottom.
2. File the top right side of the radio subdash opening so the side is straight up and down.
3. Remove the Mustang mounting tabs for this application.

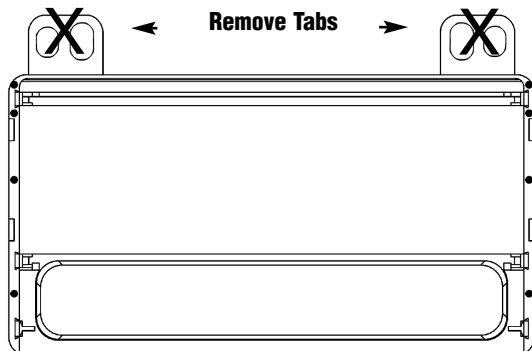

Spacer Nubs
*See Notes
on Page 1

2001-04 Ford Mustang

DASH DISASSEMBLY:

- 1 For Stickshift models-Twist off the shift knob (counter clockwise)and remove.
- 2 Gently lift up on the trim around the gear shift lever, disconnect the harness and slide the rubber boot off the end of the shifter knob.
- 3 Gently unsnap the trim bezel from around the radio, disconnect the harnesses and remove the trim bezel.
- 4 Remove the (4) 9/32 screws securing the radio to the subdash.
- 5 Slide the Radio forward, disconnect the harnesses an antenna lead and remove the radio

2002-05 Ford Explorer/Mercury Mountaineer

DASH DISASSEMBLY:

- 1 Gently pry outward on dash trim panel & remove.
- 2 Remove (2) screws securing radio to sub-dash.
- 3 Pull radio forward, disconnect wire harness & antenna lead & remove radio.

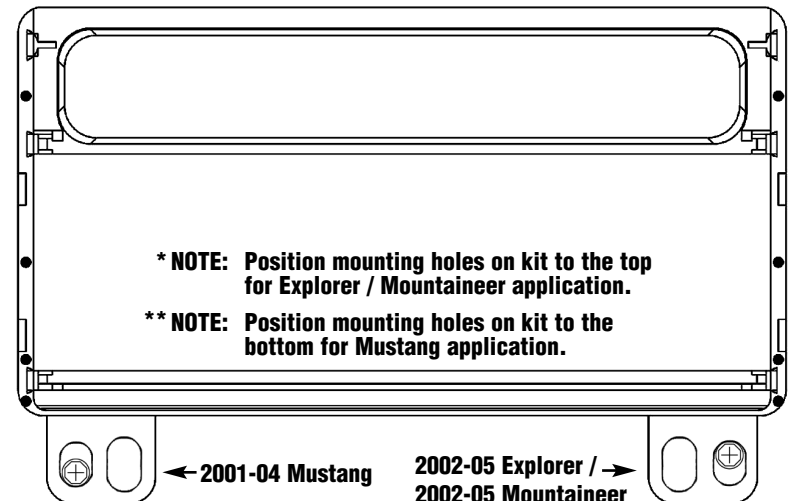

**Mustang

(Mounting Tabs)

*Explorer /
Mountaineer



(Mounting Spacers)

NOTES:

1. Pocket must be on top.
2. Attach mounting spacers to backside of mounting tabs (if desired).
3. Attach a backstrap from the back of the pocket to the backstrap hole on your radio.

2003-06 Ford Expedition w/out Factory Navigation

DASH DISASSEMBLY:

1. Set the emergency brake.
2. Remove the (2) 9/32 screws from above the instrument gauges.
3. Lower the steering column all the way down.
4. Carefully pry outward on the dash trim bezel.
5. Disconnect the wire harnesses from the headlamp switches and the climate controls and remove the panel.
6. Remove the (2) 9/32 screws securing the factory radio to the sub-dash.
7. Pull the radio forward, disconnect the wire harnesses and antenna lead and remove radio.

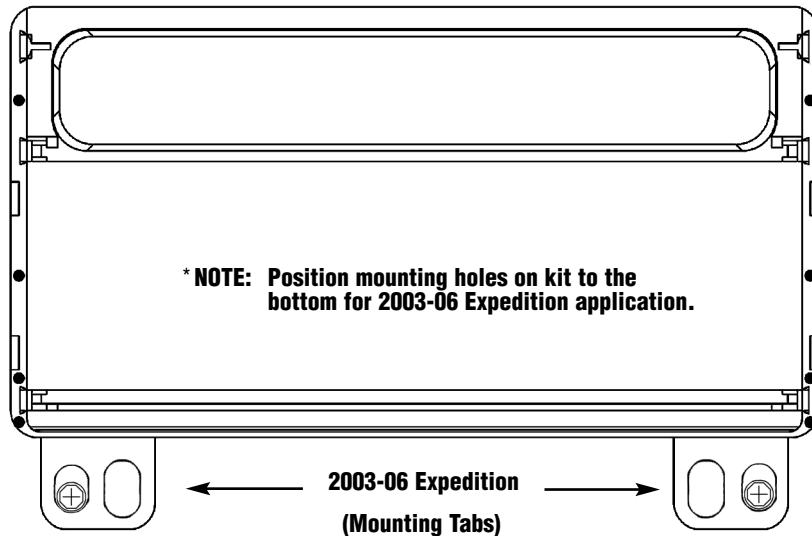

NOTES:

1. Pocket must be on top.
2. Attach mounting spacers to backside of mounting tabs (if desired).
3. Attach a backstrap from the back of the pocket to the backstrap hole on your radio.

1997-08 Ford Econoline Van (Club Wagon)

2000-05 Ford Excursion

2004 Ford F-150 Heritage

1999-03 Ford F-Series (All)

1995-11 Ford Ranger

1999-03 Ford Windstar

1995-10 Mazda B-Series P/U

NOTES:

1. This kit may be mounted in vehicle dash with pocket on top or bottom.
2. For all ISO Mount applications, you must use the factory style rear support bracket.
3. Remove the Mustang mounting tabs for these applications.

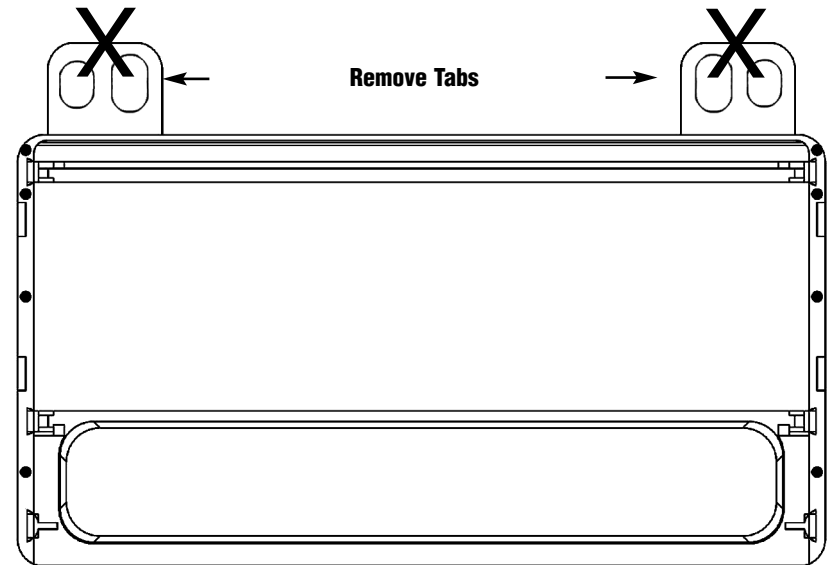

Spacer Nubs
* See Notes on Page 1