

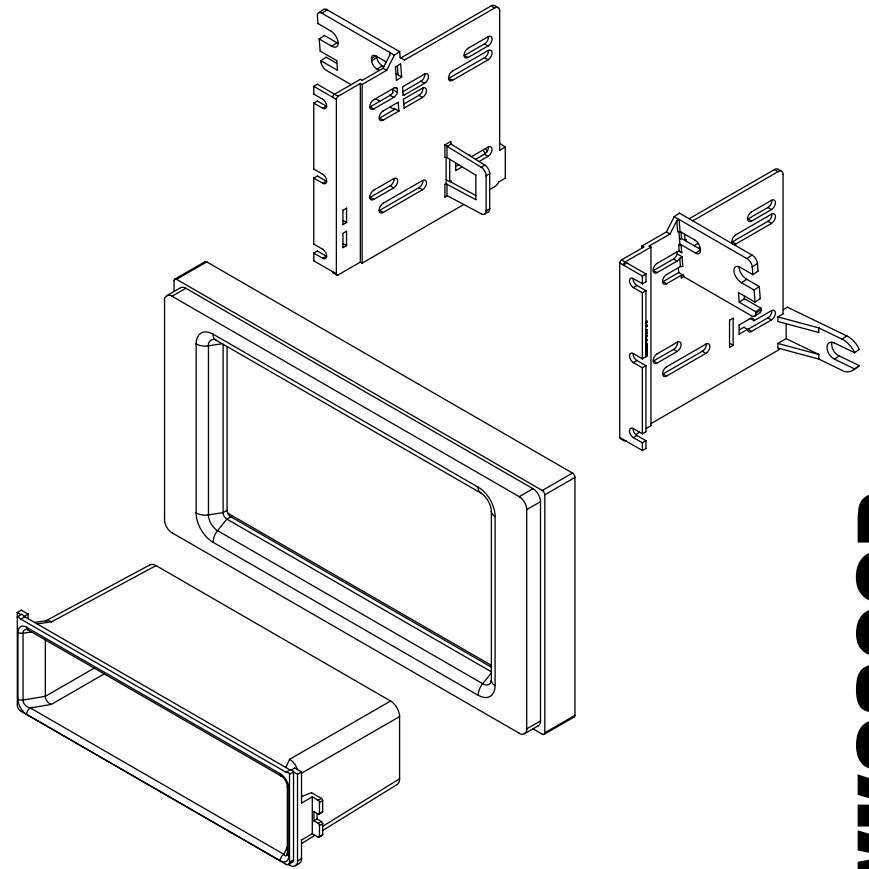

**American
International**
Car Stereo Installation Kits & Accessories



TOYK932GB Mounting Kit



www.aampglobal.com www.aius.net

2500 East Francis Street Ontario, CA 91761, U.S.A.

Sales: (800) 477-2267

Intl: (727) 572-9255

Support: 888-228-5560

VEHICLE APPLICATION

Toyota
2016 PRIUS

IT0YK932GB

DASH DISASSEMBLY INSTRUCTIONS

1. Using a soft tool unsnap side panel on passenger side of dash, located in the door jam.
2. From the are now exposed, using a soft tool, pop up the button on the grommet that is engaged to dash trim bezel.
3. Gently unsnap and remove dash trim bezel, that includes the climate controls and air vents and surrounds the radio and above the glove box.
4. Remove (4) 10 MM screws securing the radio mounting brackets
5. Remove factory radio and disconnect all wire harnesses.

KIT ASSEMBLY INSTRUCTIONS

Single ISO Mount Application

1. Insert pocket into lower section of the brackets and snap into rear pocket support tabs.
2. Install brackets to rear of main frame using the (6) screws provided.
3. Insert ISO mountable radio between ISO mount brackets and loosely attach to sides of radio using screws provided with radio when possible, or screws supplied with kit.
4. Using the main frame of the as a guide, slide radio forward or backward for desired look and then tighten screws to the radio.

Note: Attach a rear support bracket to the rear of the new radio and adjust as necessary to support the weight of the radio. Suggested

Figure A

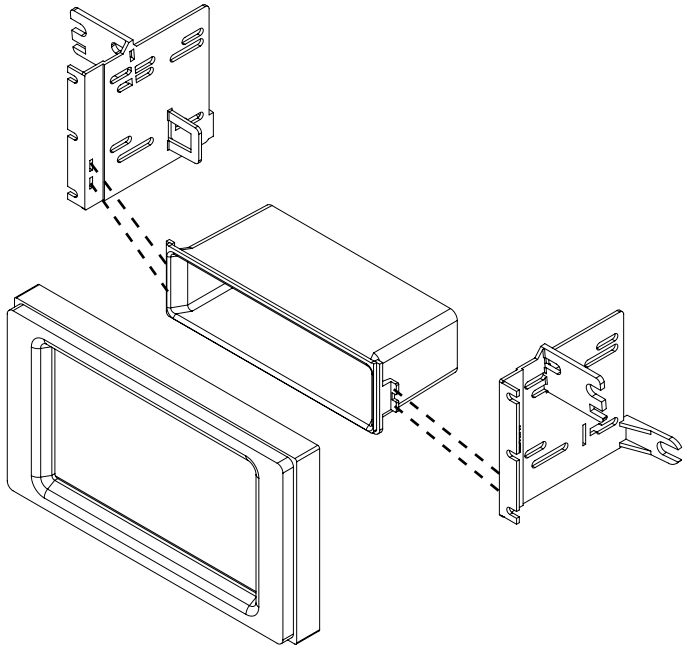

DOUBLE DIN INSTALLATION INSTRUCTIONS

Double DIN ISO Mount Application

See Fig B for bracket tab removal.

1. Install brackets to rear of main frame using the (6) screws provided.
2. Insert ISO mountable radio between ISO mount brackets and loosely attach to sides of radio using screws provided with radio when possible, or screws supplied with kit.
3. Using the main frame of the as a guide, slide radio forward or backward for desired look and then tighten screws to the radio.

Note: Attach a rear support bracket to the rear of the new radio and adjust as necessary to support the weight of the radio. Suggested.

Figure B

