



## Kia Soul (with NAV) 2014-2019

Visit [MetraOnline.com](http://MetraOnline.com) for more detailed information about the product and up-to-date vehicle specific applications

### KIT FEATURES

- ISO DIN radio provision with pocket
- ISO DDIN radio provision
- Includes climate display for fan speed, mode, and temp, which was displayed on the factory radio
- Includes an Axxess interface and wiring harness
- Includes an AX-CAM6V and antenna adapter for a complete installation
- Painted high gloss black

### KIT COMPONENTS

- A) Radio/climate trim panel with climate display
- B) Radio brackets
- C) Pocket
- D) Heated seat blank plugs
- E) (4) #8 x 3/8" Phillips screws
- F) (6) Panel clips
- G) Axxess interface and wiring harness (not shown)

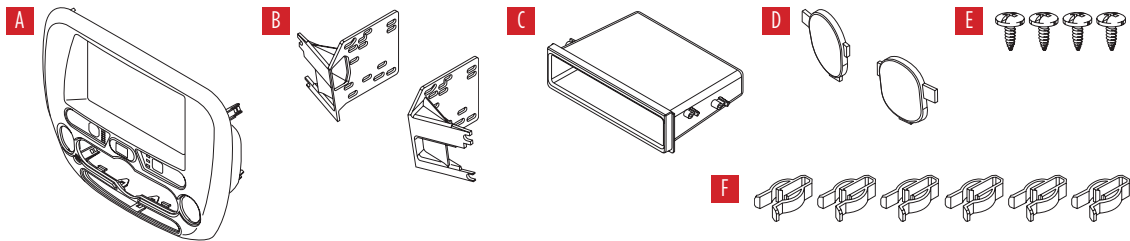

### TABLE OF CONTENTS

Dash Disassembly.....	2
Kit Preparation.....	2
Kit Assembly	
–ISO DIN radio provision with pocket.....	3
–ISO DDIN radio provision.....	3
Axxess Interface Installation.....	4-11

### WIRING & ANTENNA CONNECTIONS (sold separately)

- Wiring harness: Included with kit
- Antenna adapter: Included with kit
- Steering wheel control interface: Included with kit
- 12v to 6v camera step-down: AX-CAM6V Included with kit

### TOOLS REQUIRED

- Panel removal tool
- Phillips screwdriver

**Attention!** Let the vehicle sit with the key out of the ignition for a few minutes before removing the factory radio. When testing the aftermarket equipment, ensure that all factory equipment is connected before cycling the key to ignition.

## DASH DISASSEMBLY

1. Unclip the climate panel surrounding the radio and set to the side. (Figure A)
2. Remove (4) Phillips screws securing the radio. Slide the radio out, then unplug and remove the radio. (Figure B)

*Continue to Kit Preparation*

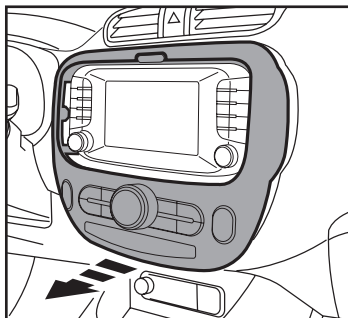

(Figure A)

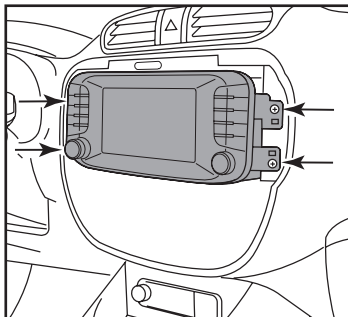

(Figure B)

## KIT PREPARATION

### From the factory climate panel:

1. Remove (4) Phillips screws securing the climate controls and passenger airbag switch panel, then remove the components. (Figure A)

### To the 99-7388HG radio/climate trim panel with climate display:

2. If the vehicle is not equipped with heated seats, snap in the heated seat blank plugs. (Figure B)
3. Secure the climate controls and passenger airbag switch panel using the factory screws. (Figure C)

*Continue to Kit Assembly*

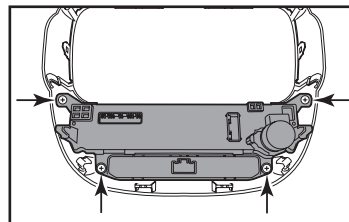

(Figure A)

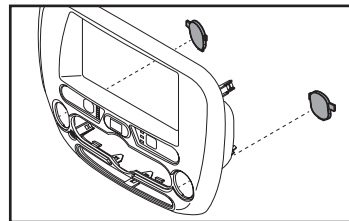

(Figure B)

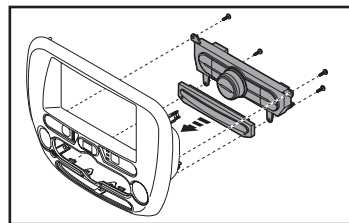

(Figure C)

## KIT ASSEMBLY

### ISO DIN radio provision with pocket

1. Secure the *radio brackets* to the *pocket* using the (4) #8 x 3/8" Phillips screws provided. (Figure A)
2. Remove the metal DIN sleeve and trim ring from the aftermarket radio.
3. Slide the radio into the bracket/pocket assembly, then secure it to the assembly using the screws supplied with the radio. (Figure B)

*Continue to Axxess Interface Installation*

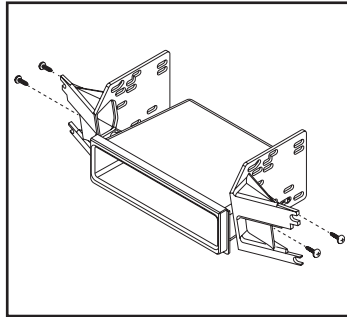

(Figure A)

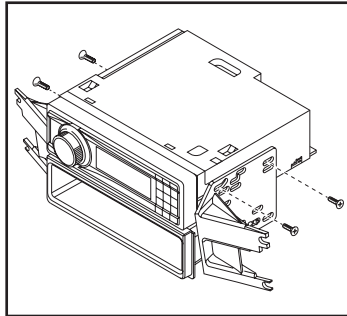

(Figure B)

### ISO DDIN radio provision

1. Secure the *radio brackets* to the radio using the screws supplied with the radio. (Figure A)

*Continue to Axxess Interface Installation*

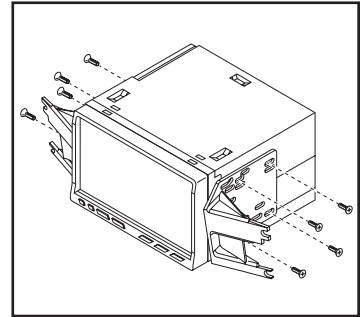

(Figure A)

# AXXESS INTERFACE INSTALLATION

## INTERFACE FEATURES

---

- Provides NAV outputs (parking brake, reverse, speed sense)
- Retains audio controls on the steering wheel
- Retains the factory backup camera
- Includes an AX-CAM6V 12-to-6V step-down for the factory camera
- Retains the factory AUX-IN jack
- Retains balance
- Micro-B USB updatable

## INTERFACE COMPONENTS

---

- Axxess interface
- AX-HYKIA-SPDIF interface
- AX-CAM6V
- 7388 wiring harness (a) (labeled LD-SOULAMP)
- 7388 wiring harness (b) (labeled LD-SOULAMP2)
- 16-pin harness with stripped leads
- Female 3.5mm connector with stripped leads

## TABLE OF CONTENTS

---

Connections.....	5-6
Installing the Axxess Interface and AX-HYKIA-SPDIF .....	6
Programming the Axxess Interface and Climate Display.....	7
Final Assembly.....	7
Audio Level Adjustment.....	7
Steering Wheel Control Settings .....	8-11
- L.E.D. feedback	
- Changing radio type	
- Remapping the steering wheel control buttons	
- Dual assignment instructions (long button press)	
Troubleshooting.....	11

## TOOLS REQUIRED

---

- Crimping tool and connectors, or solder gun, solder, and heat shrink
- Tape • Wire cutter • Zip ties • Small flat-blade screwdriver

## CONNECTIONS

### From the 16-pin harness with stripped leads to the aftermarket radio:

- Connect the **Red** wire to the accessory wire.
- Connect the **Blue/White** wire to the amp turn on wire. This wire must be connected to hear sound from the factory amplifier.
- Connect the **Gray** wire to the right front positive speaker output.
- Connect the **Gray/Black** wire to the right front negative speaker output.
- Connect the **White** wire to the left front positive speaker output.
- Connect the **White/Black** wire to the left front negative speaker output.
- Tape off and disregard the following (9) wires, they will not be used in this application: **Blue/Pink, Brown, Green, Green/Black, Green/Purple, Light Green, Orange/White, Purple, Purple/Black**

### From the 7388 harness to the aftermarket radio:

There are (2) 7388 harnesses. Harness (a) is for 2018-up models, and harness (b) is for 2017 models.

- Connect the **Black** wire to the ground wire, and also to the **Black** wire from the AX-CAM6V.  
**Note:** For harness (a) only, connect the **Black** wire labeled “CAMERA GROUND” as well.
- Connect the **Yellow** wire to the battery wire.
- Connect the **Red** wire labeled “6-volt camera power” to the **Blue/Red** wire from the AX-CAM6V.
- Connect the **Blue** wire to the power antenna wire.
- If the aftermarket radio has an illumination wire, connect the **Orange** wire to it.

The following (3) wires are only for multimedia/navigation radios that require these wires.

- Connect the **Blue/Pink** wire to the speed sense wire.
- Connect the **Green/Purple** wire to the reverse wire, and also to the **Blue/White** wire from the AX-CAM6V.
- Connect the **Light Green** wire to the parking brake wire.
- If retaining the factory AUX-IN jack, connect the **Red** and **White** RCA jacks to the audio AUX-IN jacks.
- Connect the **Yellow** RCA jack to the backup camera input.

### 3.5mm jack steering wheel control retention:

The 3.5mm jack is to be used to retain audio controls on the steering wheel.

- **For the radios listed below:** Connect the *female 3.5mm connector with stripped leads*, to the male 3.5mm SWC jack from the 7388 harness. Any remaining wires tape off and disregard:
  - **Eclipse:** Connect the steering wheel control wire, normally **Brown**, to the **Brown/White** wire from the connector. Then connect the remaining steering wheel control wire, normally **Brown/White**, to the **Brown** wire from the connector.
  - **Metra OE:** Connect the steering wheel control Key 1 wire (**Gray**) to the **Brown** wire.
  - **Kenwood or select JVC with a steering wheel control wire:** Connect the **Blue/Yellow** wire to the **Brown** wire.

**Note:** If the **Kenwood** radio auto detects as a **JVC**, manually set the radio type to **Kenwood**. See the instructions under **Changing Radio Type**.

- **XITE:** Connect the steering wheel control SWC-2 wire from the radio to the **Brown** wire.
- **Parrot Asteroid Smart or Tablet:** Connect the 3.5mm jack into the AX-SWC-PARROT (sold separately), and then connect the 4-pin connector from the AX-SWC-PARROT into the radio.

**Note:** The radio must have rev. 2.1.4 or higher software.
- **Universal “2 or 3 wire” radio:** Connect the steering wheel control wire, referred to as Key-A or SWC-1, to the **Brown** wire from the connector. Then connect the remaining steering wheel control wire, referred to as Key-B or SWC-2, to the **Brown/White** wire from the connector. If the radio comes with a third wire for ground, disregard this wire. **Note:** After the interface has been programmed to the vehicle, refer to the manual provided with the radio for assigning the SWC buttons. Contact the radio manufacturer for more information.
- **For all other radios:** Connect the 3.5mm jack from the 7388 harness into the jack from the aftermarket radio designated for an external steering wheel control interface. Please refer to the aftermarket radios manual if in doubt as to where the 3.5mm jack should connect to.

### With the key in the off position:

1. Connect the *16-pin harness with stripped leads*, and the *7388 harness*, into the Axcess interface.
2. Connect the *7388 harness* to the AX-HYKIA-SPDIF interface.
3. Connect the *7388 harness* to the *climate display*.
4. Locate the factory antenna connector in the dash and complete all necessary connections to the radio. Use the antenna adapter provided to adapt the factory antenna connector to the aftermarket radio.

**Attention!** If retaining steering wheel controls, ensure that the SWC jack/wire is connected to the radio before proceeding. If this step is skipped, the interface will need to be reset for the steering wheel controls to function.

## PROGRAMMING THE AXCESS INTERFACE AND CLIMATE DISPLAY

### Programming the Axcess interface:

1. For the steps below, the L.E.D. located inside the interface can only be seen while active. The interface does not need to be opened to see the L.E.D.
2. Start the vehicle. The L.E.D. will initially turn on solid **Green**, then turn off for a few seconds while it auto detects the radio installed.
3. The L.E.D. will then flash **Red** up to (18) times indicating which radio is connected to the interface, and then turn off for a couple of seconds. Pay close attention to how many **Red** flashes there are. This will help in troubleshooting, if need be. Refer to the L.E.D. feedback section for more information.
4. After a couple seconds the L.E.D. will turn on solid **Red** while the interface auto detects the vehicle. The radio will shut off at this point. This process should take 5 to 30 seconds.
5. Once the vehicle has been auto detected by the interface, the L.E.D. will turn on solid **Green**, and the radio will come back on, indicating programming was successful.

### Programming the climate display:

1. Turn the parking lights on.
2. Turn the vehicles light dimmer all the way down, then all the way up.
3. Turn the lights off.
4. Test all functions of the installation for proper operation before reassembling the dash. Refer to the **Steering Wheel Control Settings** section for customizing the buttons, if so desired. Refer also to the **Audio Level Adjustment** section for adjusting the amplifier gain, if need be.

## FINAL ASSEMBLY

1. Secure the radio assembly to the dash using the factory screws.
2. Reassemble the dash in reverse order of disassembly to complete the installation.

## AUDIO LEVEL ADJUSTMENT

1. With the vehicle and radio turned on, turn the volume up 3/4 of the way.
2. With a small flat-blade screwdriver, adjust the potentiometer clockwise to raise the audio level; counterclockwise to lower the audio level.
3. Once at a desired level, audio level adjustment is complete.

## STEERING WHEEL CONTROL SETTINGS

### L.E.D. feedback

The (18) **Red** L.E.D. flashes represent what brand radio the Axxess interface believes it is connected to. Each flash represents a different radio Manufacturer. For example, if you are installing a JVC radio, the Axxess interface will flash **Red** (5) times, and then stop. Following is a legend that dictates which radio Manufacturer corresponds to which flash.

### L.E.D. feedback legend

1 flash - Eclipse (Type 1) †	7 flashes - Alpine *	13 flashes - LG
2 flashes - Kenwood ‡	8 flashes - Visteon	14 flashes - Parrot **
3 flashes - Clarion (Type 1) †	9 flashes - Valor	15 flashes - XITE
4 flashes - Sony/Dual	10 flashes - Clarion (Type 2) †	16 flashes - Phillips
5 flashes - JVC	11 flashes - Metra OE	17 flashes - TBA
6 flashes - Pioneer/Jensen	12 flashes - Eclipse (Type 2) †	18 flashes - JBL

**\* Note:** If the Axxess interface flashes **Red** (7) times, and you do not have an Alpine radio connected to it, that means the Axxess interface does not detect a radio connected to it. Verify that the 3.5mm jack is connected to the correct steering wheel jack/wire in the radio.

**\*\* Note:** The AX-SWC-PARROT is required (sold separately). Also, the Parrot radio must have rev. 2.1.4 or higher software.

**† Note:** If you have a Clarion radio and the steering wheel controls do not work, change the radio type to the other Clarion radio type; same for Eclipse. The following section explains how to do this.

**‡ Note:** If you have a Kenwood radio and the L.E.D. feedback comes back showing as a JVC radio, change the radio type to Kenwood. The following section explains how to do this.

**Attention:** The Axxess Updater App can also be used to program the following (3) sub-sections as well, pending that the Axxess interface has been programmed.

*Continued on the next page*



## STEERING WHEEL CONTROL SETTINGS (CONT.)

### Changing radio type

If the L.E.D. flashes do not match the radio you have connected, you must manually program the Axxess interface to tell it what radio it is connected to.

1. After (3) seconds of turning the key on, press and hold the **Volume Down** button on the steering wheel until the L.E.D. in the Axxess interface goes solid.
2. Release the **Volume Down** button; the L.E.D. will go out indicating the Axxess interface is in **Changing Radio Type** mode.
3. Refer to the **Radio Legend** to know which radio number you would like to have programmed.
4. Press and hold the **Volume Up** button until the L.E.D. goes solid, and then release. Repeat this step for the desired radio number you have selected.
5. Once the desired radio number has been selected, press and hold the **Volume Down** button on the steering wheel until the L.E.D. goes solid. The L.E.D. will remain on for about (3) seconds while it stores the new radio information.
6. Once the L.E.D. goes out, the **Changing Radio Type** mode will then end. You can now test the steering control wheel controls.

**Note:** If at any time the user fails to press any button for a period longer than (10) seconds, this process will abort.

### Radio legend

1 flash - Eclipse (Type 1) †	7 flashes - Alpine *	13 flashes - LG
2 flashes - Kenwood ‡	8 flashes - Visteon	14 flashes - Parrot **
3 flashes - Clarion (Type 1) †	9 flashes - Valor	15 flashes - XITE
4 flashes - Sony/Dual	10 flashes - Clarion (Type 2) †	16 flashes - Philips
5 flashes - JVC	11 flashes - Metra OE	17 flashes - TBA
6 flashes - Pioneer/Jensen	12 flashes - Eclipse (Type 2) †	18 flashes - JBL

*Continued on the next page*

## STEERING WHEEL CONTROL SETTINGS *(CONT.)*

### Remapping the steering wheel control buttons

Once the Axxess interface has been programmed, the button assignment for the steering wheel controls may be reassigned if so desired. For example, if the **Seek Up** button is preferred to be the **Mute** button instead. Follow the steps below to remap the steering wheel control buttons.

1. Ensure the Axxess interface is visible so you can see the L.E.D. flashes to confirm button recognition.

**Tip:** Turning the radio off is recommended.

2. Within the first twenty seconds of turning the ignition on, press and hold the **Volume Up** button on the steering wheel until the L.E.D. goes solid.
3. Release the **Volume Up** button, the L.E.D. will then go out; The **Volume Up** button has now been programmed.
4. Follow the list in the **Button Function Legend** to reference the order in which the steering wheel control buttons need to be programmed.

**Note:** If the next function on the list is not on the steering wheel, press the **Volume Up** button for (1) second until the L.E.D. comes on to skip that function, and then release the **Volume Up** button. This will tell the Axxess interface that this function is not available, and it will move on to the next function.

5. To complete the remapping process, press and hold the **Volume Up** button until the L.E.D. in the Axxess interface goes out.

### Button Function Legend

1. Volume-Up	7. Preset-Up	13. On-Hook
2. Volume-Down	8. Preset-Down	14. Off-Hook
3. Seek-Up/Next	9. Power	15. Fan-Up *
4. Seek-Down/Prev	10. Band	16. Fan-Down *
5. Source/Mode	11. Play/Enter	17. Temp-Up *
6. Mute	12. PTT (Push to Talk)	18. Temp-Down *

\* Not applicable in this application

**Note:** Some radios may not have these commands. Please refer to the manual provided with the radio, or contact the radio manufacturer for specific commands recognized by that particular radio.

*Continued on the next page*

## STEERING WHEEL CONTROL SETTINGS (CONT.)

### Dual assignment instructions (long button press)

The Axxess interface has the capability to assign (2) functions to a single button, except **Volume Up** and **Volume Down**. Follow the steps below to program the button(s) to the desired setting.

**Note:** **Seek Up** and **Seek Down** come pre-programmed as **Preset Up** and **Preset Down** for a long button press.

1. Turn the key to ignition but do not start the vehicle.
2. Press and hold the desired steering wheel control button for (10) seconds, or until the L.E.D. flashes rapidly. At this point release the button; the L.E.D. will then go solid.
3. Press and release the **Volume Up** button the number of times corresponding to the new button number selected. Refer to the **Dual Assignment Legend**. The L.E.D. will flash rapidly while the **Volume Up** button is being pressed, and then go back to a solid L.E.D. once released. Proceed to the next step once the **Volume Up** button has been pressed the desired number of times.

**Caution:** If more than (10) seconds elapses between pressing the **Volume Up** button, this procedure will abort, and the L.E.D. will go out.

4. Press the desired button to store it to memory. The L.E.D. will now go out indicating the new information has been stored to memory.

**Note:** These steps must be repeated for each button desired to assign a dual assignment feature to. To reset a button back to its default state, repeat Step 1, then press the **Volume Down** button. The L.E.D. will go out, and the dual assignment feature for that button will be erased.

### Dual Assignment legend

- |                   |                        |                 |
|-------------------|------------------------|-----------------|
| 1. Not allowed    | 7. Preset-Up           | 13. On-Hook     |
| 2. Not allowed    | 8. Preset-Down         | 14. Off-Hook    |
| 3. Seek-Up/Next   | 9. Power               | 15. Fan-Up *    |
| 4. Seek-Down/Prev | 10. Band               | 16. Fan-Down *  |
| 5. Mode/Source    | 11. Play/Enter         | 17. Temp-Up *   |
| 6. ATT/Mute       | 12. PTT (Push to Talk) | 18. Temp-Down * |

\* Not applicable in this application

## TROUBLESHOOTING

### Resetting the Axxess interface

1. The **Blue** reset button is located inside the Axxess interface, between the two connectors. The button is accessible outside the Axxess interface, no need to open the Axxess interface.
2. Press and hold the reset button for (2) seconds, then let go to reset the Axxess interface.
3. Refer to **Programming the Axxess Interface** from this point.



**99-7388HG**  
INSTALLATION INSTRUCTIONS



If you are having difficulties with the installation of this product, contact our Tech Support line either by phone at **1-800-253-TECH**, or email at **techsupport@metra-autosound.com**. Before doing so, look over the instruction booklet a second time and ensure that the installation was performed exactly as the instruction booklet is stated. Have the vehicle apart and ready to perform troubleshooting steps before contacting Metra/Axxess Tech Support.



**KNOWLEDGE IS POWER**

Enhance your installation and fabrication skills by enrolling in the most recognized and respected mobile electronics school in our industry. Log onto [www.installerinstitute.com](http://www.installerinstitute.com) or call 800-354-6782 for more information and take steps toward a better tomorrow.



**Metra recommends MECP certified technicians**