

For information about other American International automotive accessories visit our website at:

<http://www.americaninternational.net>

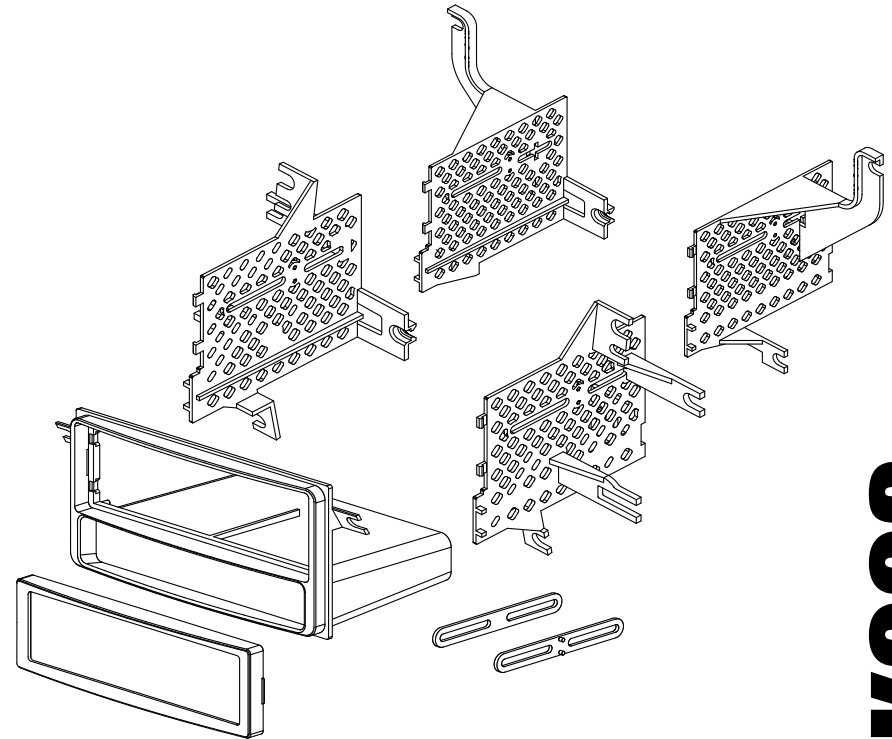

American International
Car Stereo Installation Kits & Accessories



TOYK993 Mounting Kit



American International

Automotive Products Division

1040 Avenida Acaso • Camarillo, CA 93012, U.S.A.

USA Sales (800) 336-6500 • Canada Sales (888) 922-3006 • USA Fax (805) 388-7950

For information about other accessories visit our website at:

<http://www.americaninternational.net>

CUSTOMER HELP LINE

USA 800-323-4329 • Canada 800-245-8777

IT0YK969

VEHICLE APPLICATIONS

Toyota

2007-12 YARIS

DIN MOUNT INSTRUCTIONS

1. Follow instructions from steps 1&2 of ISO mount instructions below.
2. Insert DIN sleeve from your new radio into the upper section of the installation kit.
3. Depress the tabs from inside the sleeves opening upward, outward, and downward to secure sleeve to the installation kit.
4. Install radio into sleeve and lock into place.
5. **SUGGESTED**...Support rear of radio with back strap.

Optional use Trim Ring (ITR-969) may be used on some radios if desired.

Due to the movement of some faces on some radios our ISO Trim Ring may not be able to be used. You may also ISO mount your radio.

Your new radio must have a trim ring around the face of the radio that is designed to be easily removed. Consult your radio owner's manual.

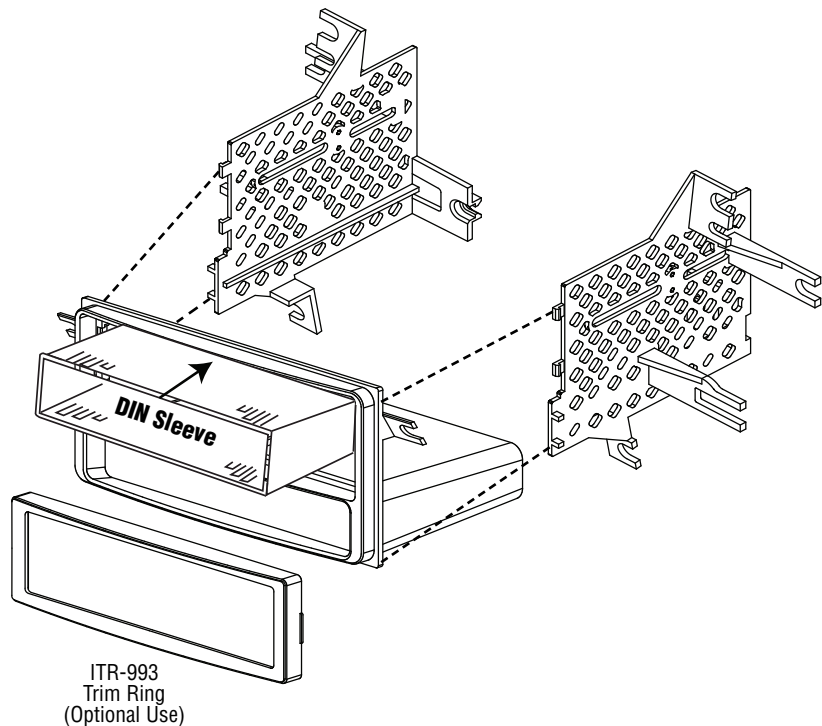

NOTES

2012 TOYOTA YARIS

DASH DISASSEMBLY

1. Carefully unclip and remove the soft trim piece from around the radio, airbag light/hazard button and passenger side air vent.
3. Carefully unclip and pry forward the radio trim bezel.
5. Remove the (4) Phillips screws securing the radio to the sub-dash.
6. Pull radio forward, disconnect the attached wire harness and antenna lead and remove radio.

KIT ASSEMBLY

FOR ISO or DIN MOUNT APPLICATIONS SEE PAGE 2 & 3

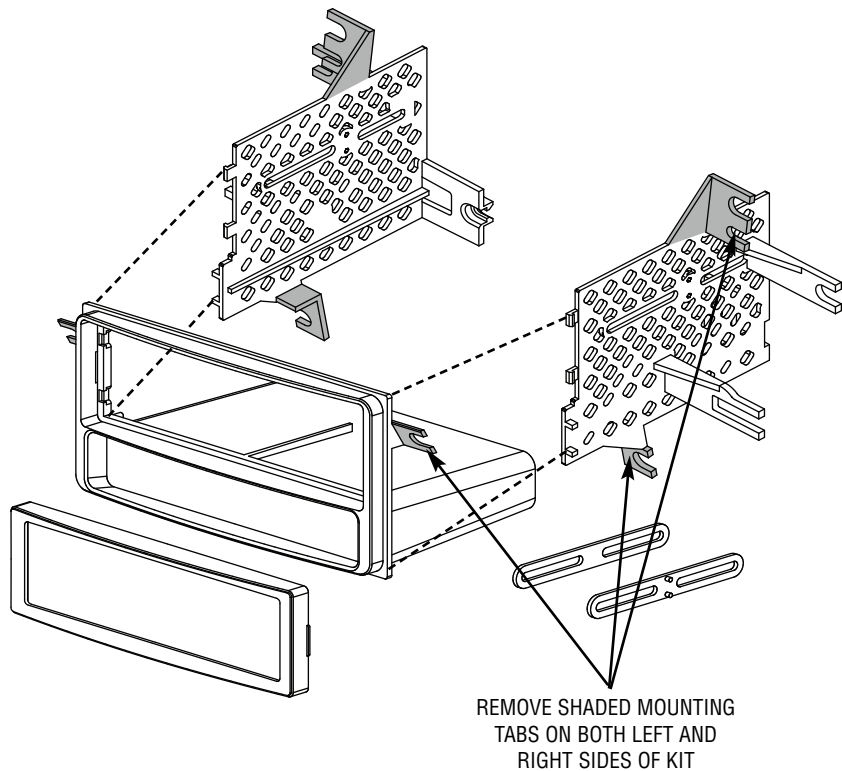

2007-2009 TOYOTA YARIS - 3 DOOR LIFTBACK ONLY

DASH DISASSEMBLY

1. Starting from lower edges, unclip the left and right side trims from around the radio and climate controls, disconnect the attached harnesses and remove trims.
2. Carefully unclip and pry forward the lower edge of the instrument gauge trim bezel.
3. Carefully unclip and pull forward the Radio/Vent trim bezel and remove.
4. Remove the (4) Phillips screws securing the radio to the sub-dash.
5. Pull radio forward, disconnect the attached wire harness and antenna lead and remove radio.

KIT ASSEMBLY

FOR ISO or DIN MOUNT APPLICATIONS SEE PAGE 2 & 3

1. Prepare mounting brackets as shown below.

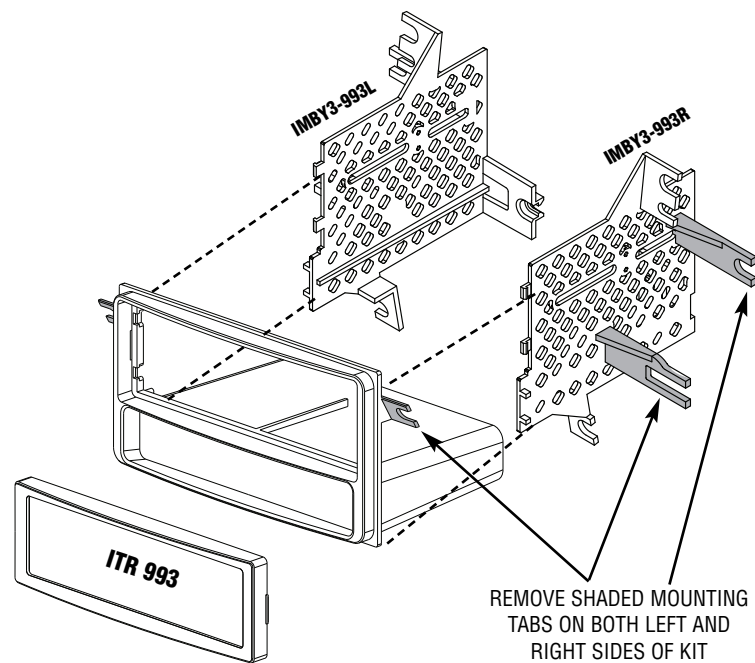

DASH DISASSEMBLY

1. Carefully unclip and remove the bottom edge trim piece from below the climate control module.
2. Starting from lower edges, unclip the left and right side trims from around the radio and climate controls and remove.
3. Carefully unclip and pry forward the lower edge of the instrument gauge trim bezel.
4. Carefully unclip and pull forward the Radio/Vent trim bezel, disconnect the attached harness and remove bezel.
5. Remove the (4) Phillips screws securing the radio to the sub-dash.
6. Pull radio forward, disconnect the attached wire harness and antenna lead and remove radio.

KIT ASSEMBLY

FOR ISO or DIN MOUNT APPLICATIONS SEE PAGE 2 & 3

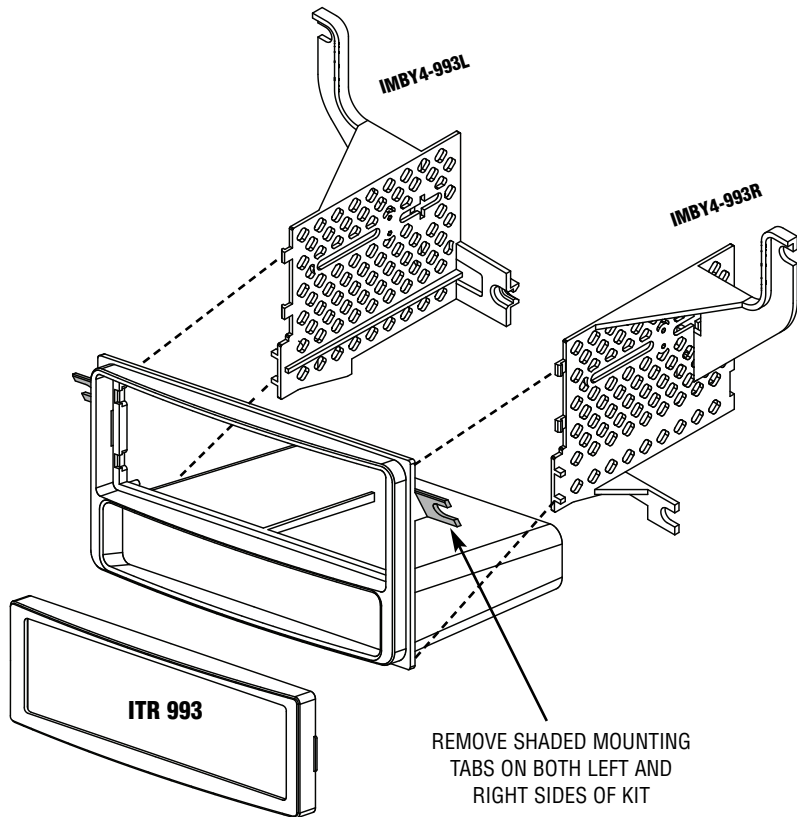

ISO MOUNT INSTALLATION INSTRUCTIONS

Note: Some radio faces are larger in size than the ITR-969 Trim Ring allows. You may need to file the Trim Ring opening larger for some radios.

1. Attach the left and right side brackets to the main bracket. See illustration below.
2. Attach left and right side brackets to the rear of the pocket using screws supplied w/kit.
3. Attach ISO Mount Spacers to the inside of upper section on both Left & Right mounting brackets as shown in Figure A.
4. Slide radio into kit from rear & attach to ISO mounting brackets using screws supplied with radio (do not tighten screws at this time). (Be sure the length of the screws DO NOT touch any electrical parts inside radio, some screws may need to be shortened.)
5. Slide radio forward or backward for your desired look and then tighten the mounting screws. Use ISO trim ring when possible.
6. **SUGGESTED**...Attach rear support strap (supplied with radio) to rear of pocket and to rear of radio.

NOTE: Optional ISO trim ring (ITR-969 included) may be used in place of after-market radio's trim ring.

