

For information about other American International automotive accessories visit our website at:

<http://www.americaninternational.net>

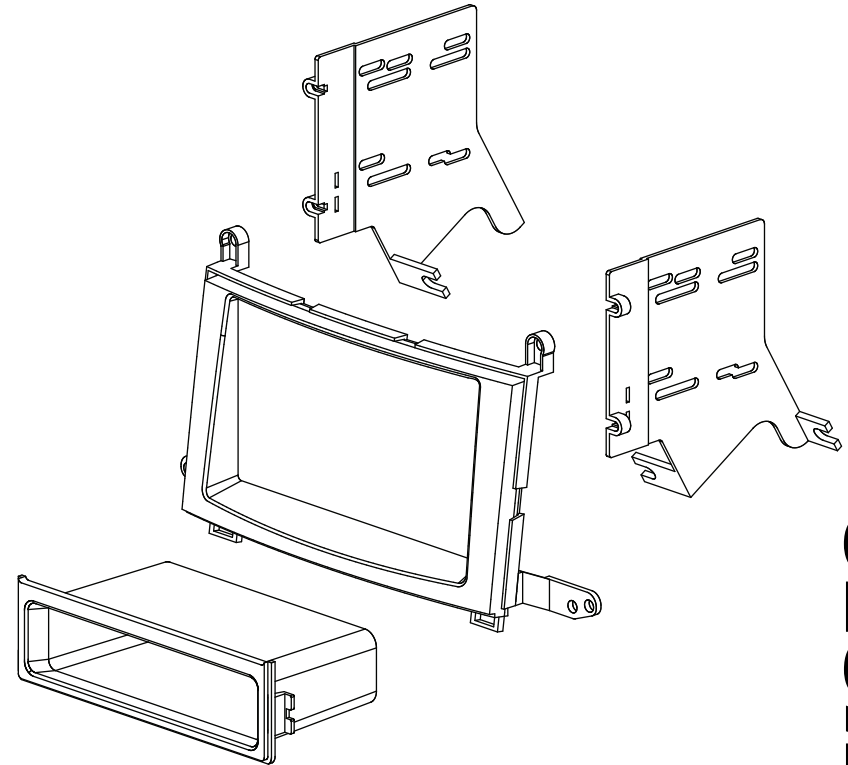

**American
International**
Car Stereo Installation Kits & Accessories



TOY-K976 Mounting Kit



American International

Automotive Products Division

1040 Avenida Acaso • Camarillo, CA 93012, U.S.A.

USA Sales (800) 336-6500

Canada Sales (888) 922-3006 • USA Fax (805) 388-7950

CUSTOMER HELP LINE

USA 800-323-4329 • Canada 800-245-8777

iTOYK976

VEHICLE APPLICATIONS

Toyota

2009-11 VENZA

DASH DISASSEMBLY AND RADIO REMOVAL

1. Slide the Center console drink tray all the way back.
2. Carefully unclip and remove the Panel directly below the Climate controls.
3. Remove the screws securing the Climate control module to the sub-dash, disconnect and remove climate control module.
4. Remove the (4) 10mm Bolts securing the factory radio to the sub-dash. This will require a swivel socket adapter and extension to get to the lower left Bolt.
5. Pull the radio/Vent assembly forward, disconnect all attached harnesses and antenna lead and remove assembly.
6. Remove the (4) Phillips screws securing the Vent trim assembly from the radio and set Vent assembly aside.

KIT ASSEMBLY INSTRUCTIONS

Single ISO Mount Applications

1. This kit is an (ISO) mounting kit only.
2. The mounting sleeve of your new radio and trim ring cannot be used when ISO mounting an aftermarket radio. Your radio must have a removeable trim ring.
3. Insert left and right mounting brackets to rear of kit as shown in Figure A and secure to rear of kit fascia using (4) small phillips screws included in kit.
4. Insert pocket into lower section of kit from rear & lock into slots of mounting brackets.
5. Insert ISO mountable radio between ISO mount brackets and loosely attach to sides of radio using screws provided with radio when possible or screws supplied with kit.
6. Slide radio forward or backward for desired look and tighten screws.

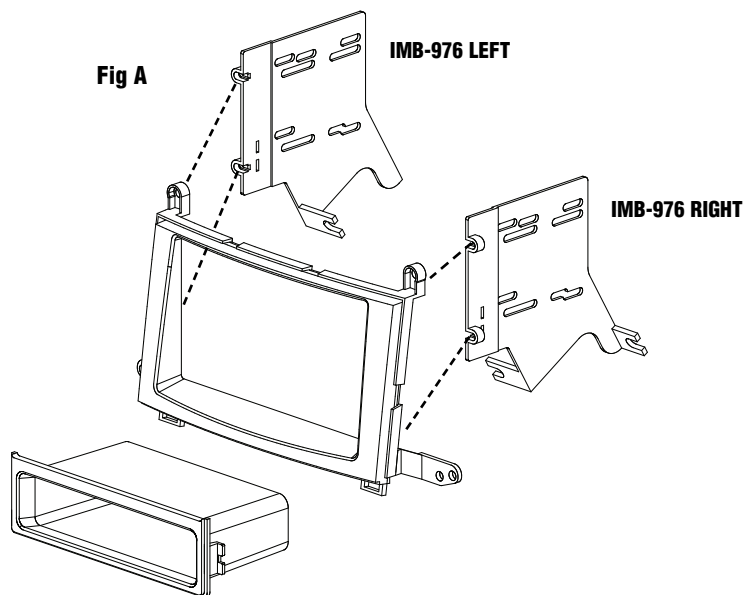

Double ISO Mount Applications

1. This kit is an (ISO) mounting kit only.
2. The mounting sleeve of your new audio/video components and trim ring cannot be used when ISO mounting an aftermarket radio. Your audio/video components must have a removeable trim ring.
3. Insert left and right mounting brackets to rear of kit as shown in Figure B and secure to rear of kit fascia using (4) small phillips screws included in kit.
4. Insert ISO mountable audio/video components between ISO mount brackets and loosely attach to sides of radio using screws provided with radio when possible or screws supplied with kit.
5. Slide audio/video components forward or backward for desired look and tighten screws.
6. Attach a rear support bracket to the rear of the new radio and adjust as necessary to support the weight of the radio.

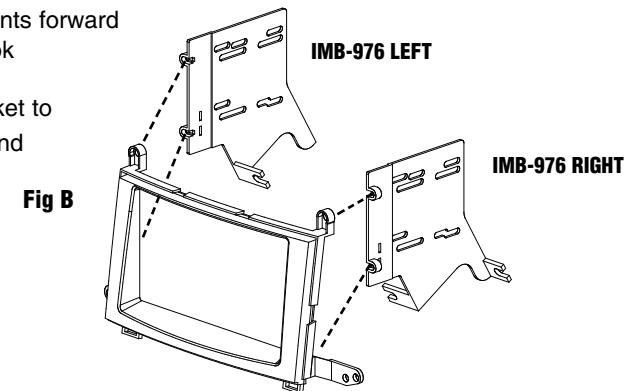

Double DIN Mount Applications

1. Cut out the center rib of the main fascia & file edges smooth as shown in Figure C.
2. Insert IMB-976 L&R into rear of kit & attach using 4 screws supplied w/kit.
3. Insert ISO mountable radio between ISO mount brackets and loosely attach to sides of radio using screws provided with radio when possible or hardware included with kit.
4. Slide radio component forward or backward for desired look and tighten screws.
5. Attach a rear support bracket to the rear of the new radio and adjust as necessary to support the weight of the radio.

