



**American  
International**

**2004-05 CHRYSLER PACIFIC**

**DASH DISASSEMBLY**

1. Using a metric Allen Wrench, remove the shifter knob. The screw is located at the front of the shift lever near the bottom.
2. Carefully lift upward on the trim from around the shift lever and remove.
3. Carefully unclip and remove the left and right trims from both sides of the radio and climate controls.
4. Remove the (4) Phillips screws securing the factory radio to the sub-dash.
5. Pull radio forward, disconnect the wire harness and antenna lead and remove radio.

**DOUBLE DIN MOUNT ASSEMBLY INSTRUCTIONS**

1. Insert DIN sleeve from your new radio into the radio opening of the installation kit.
2. Depress the tabs from inside the sleeves opening upward, outward, and downward to secure the installation kit to the sub-dash.

Fig A

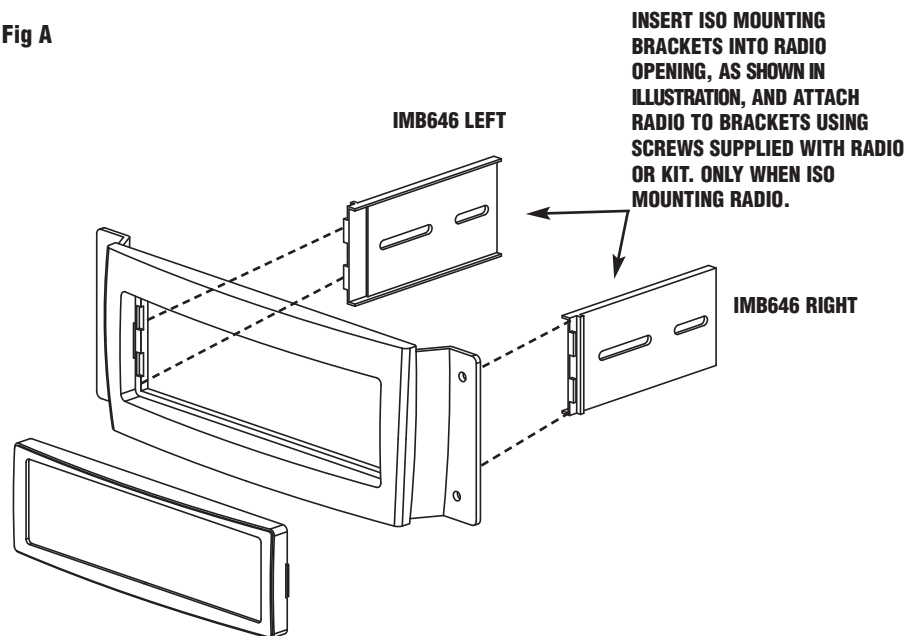

**CRK646 Mounting Kit**



**VEHICLE APPLICATIONS**

**Chrysler**  
2004-08 PACIFIC



[www.aampglobal.com](http://www.aampglobal.com) [www.aius.net](http://www.aius.net)

2500 East Francis Street Ontario, CA 91761, U.S.A.

Sales: (800) 477-2267

Intl: (727) 572-9255

Support: 888-228-5560