

For information about other American International automotive accessories visit our website at:

<http://www.aius.net>

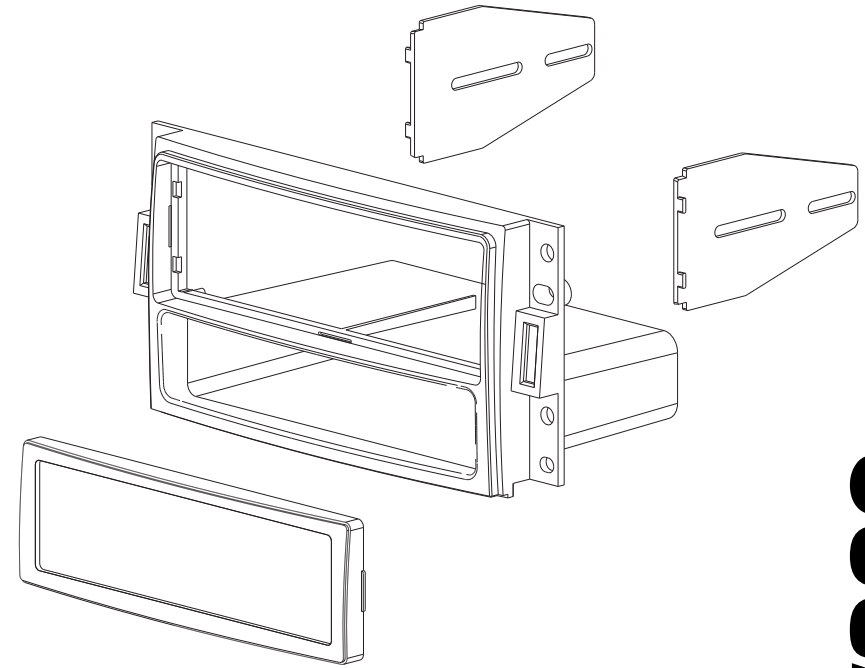

**American  
International**  
Car Stereo Installation Kits & Accessories



**GMK380 Mounting Kit**



**American International**

**WWW.AIUS.NET**

2500 East Francis Street Ontario, CA 91761, U.S.A.

USA Sales (800) 336-6500

Canada Sales (888) 922-3006

**CUSTOMER HELP LINE**

**USA 800-323-4329 • Canada 800-245-8777**

iGMK380

### VEHICLE APPLICATIONS

**Buick** 2005-07 RELAY  
2005-07 TERRAZA  
**Chevy** 2005-10 CORVETTE  
2005-08 UPLANDER  
**Hummer** 2005-09 H3  
2009 H3T  
**Pontiac** 2005-06 MONTANA SV6  
**Saturn**

TECH Ver. 11/14 PRINT Ver. 11/14

©2014 AMERICAN INTERNATIONAL INDUSTRIES, INC.

**2005-07 BUICK TERRAZA**  
**2005-08 CHEVROLET UPLANDER**  
**2005-06 PONTIAC MONTANA SV6**  
**2005-07 SATURN RELAY**

## DASH DISASSEMBLY INSTRUCTIONS

1. Carefully unclip the trim from around the radio/Climate controls and remove. (Use of a panel removal tool, or a right angle scribe tool is recommended).
2. Remove the (8) 9/32 or Phillips screws securing the Radio and Climate controls to the sub-dash.
3. Pull the Radio and Climate controls forward, lower and set the climate control out of the way, disconnect the wire harnesses and antenna lead from the rear of the factory radio and remove radio.

**2005-10 CHEVROLET CORVETTE**

## DASH DISASSEMBLY

1. Carefully lift up and remove the Ride Control switch/ cover plate located at the base of the center console, behind the Shifter.
2. Remove the (2) 9/32 screws located beneath the Ride Control/cover plate.
3. Carefully unfasten and remove the entire Radio/Climate Control trim bezel.
4. Remove the (4) 9/32 screws securing the radio to the sub-dash.
5. Pull the radio forward, disconnect all attached harnesses and antenna lead and remove radio.

**2005-09 HUMMER H3**  
**2009 HUMMER H3T**

## DASH DISASSEMBLY

1. Carefully remove trim from around radio.
2. Remove (4) 9/32 screws securing factory radio and climate controls to the sub-dash
3. Lay climate controls out of the way.
4. Pull radio and climate controls forward, disconnect all harnesses from radio and remove radio.

## DIN MOUNT INSTALLATION INSTRUCTIONS

1. Insert DIN sleeve from your new radio into the radio opening of the installation kit.
2. Depress the tabs from inside the sleeves opening upward, outward, and downward to secure sleeve to the installation kit.

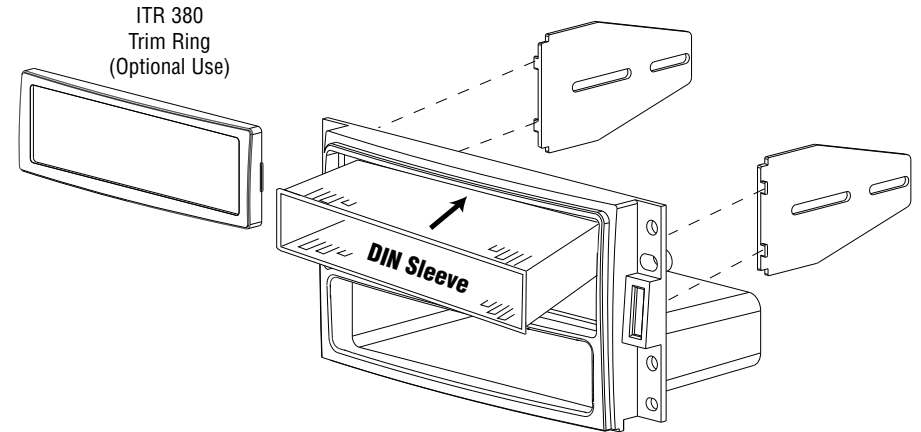

## ISO MOUNT INSTALLATION INSTRUCTIONS

1. Attach ISO brackets to the rear of the main mounting kit (see illustration above).
2. Slide radio into kit from rear & attach to ISO mounting brackets using screws supplied with radio (do not tighten screws at this time).
3. Slide radio forward or backward for your desired look and then tighten the mounting screws. Use ISO trim ring when possible.
4. Attach rear support strap (supplied with radio) to rear of pocket and to rear of radio.

