

IN-DASH INSTALLATION KIT FOR 2006-UP MAZDA MIATA / MX5 VEHICLES

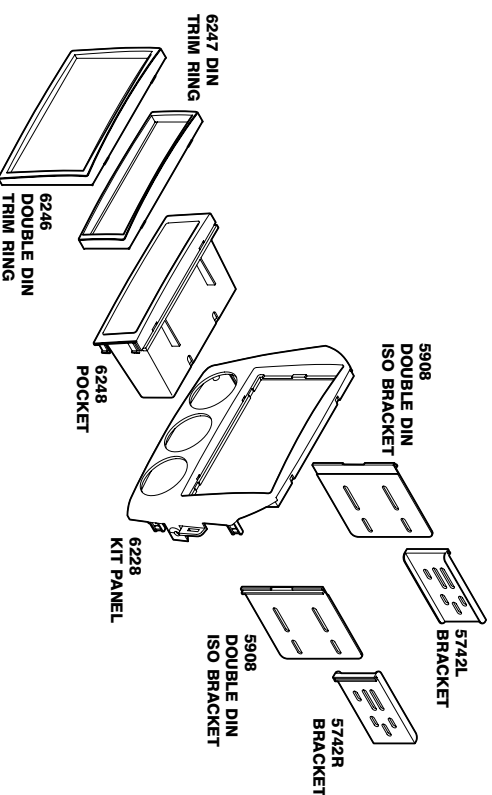

INTRODUCTION / PRELIMINARY

This premium installation kit is for MA1532B 2006-Up Mazda Miata / MX5 vehicles. Included are all the parts you need to mount your car stereo/cassette or CD player into your vehicle's dash. Refer to the individual instruction in this manual to remove your vehicle's factory radio and assemble the kit.

CAUTION:

DISCONNECT YOUR VEHICLES NEGATIVE BATTERY TERMINAL BEFORE THE INSTALLATION TO HELP PREVENT ELECTRICAL DAMAGE. WE RECOMMEND THE USE OF A VOLT/OHM METER OVER A TEST LIGHT TO CHECK WIRING. A TEST LIGHT OR GROUNDED WIRE PROBE CAN CAUSE DAMAGE TO THE VEHICLES COMPUTER AND/OR DIAGNOSTIC SYSTEMS. AVOID ALL FACTORY AIRBAG WIRING - AIRBAGS CAN ACCIDENTALLY DEPLOY CAUSING SERIOUS INJURY OR DEATH.

NOTES:

- See your vehicle's instructions for any special tools your installation might require.
- Read all instructions accompanying your car stereo/cassette player for proper wiring and mounting instructions.

FACTORY WIRING CODES

For Factory Wiring Codes go to: www.scosche-cars.com

<p>CAR STEREO CONNECTORS</p> <p>PROVIDE EASY CONNECTION OF YOUR CAR STEREO TO FACTORY WIRING HARNESS.</p> <p>MAO3B</p> <p>2000-Up Select Mazda</p>	<p>MAO3B</p> 
--	---

LIABILITY DISCLAIMER

This instruction booklet is based on carefully documented data and research of automobile dash disassembly, wire harness/codes and information pertaining to installation of this kit (MA1532B) in 2006-Up Mazda Miata / MX5 GM Vehicles. Scosche Industries, Inc. can not be held responsible for discrepancies/inconsistencies that may occur due to the automobile manufacturing changes or options, or damage that may occur in the automobile during the installation of components while using this booklet.

If you have any further questions, call our toll free technical help line at: **1-800-621-3695x3**

VEHICLE DISASSEMBLY

2006-Up Mazda Miata / MX5

RADIO REMOVAL:

1. Remove plastic knee guard panel.
2. Extract bolts securing knee guard panel.
3. Extract 1 hidden Phillips Head Screw securing side of radio.
4. Unsnap lower side trim panel on each side of the radio by pulling back on them and unstrap them.
5. Extract 1 Phillips Head Screw securing factory radio on each side.
6. Using a Panel Removal Tool, unstrap the parameter of the radio. Lift away disconnect and remove.

MOUNTING THE RADIO

MOUNTING A/C CONTROLS

1. Retain factory A/C controls and factory screws to be mounted onto panel.
2. Align A/C control unit and insert into panel. (Use factory screws)
3. Using factory screws, attach A/C unit to panel.

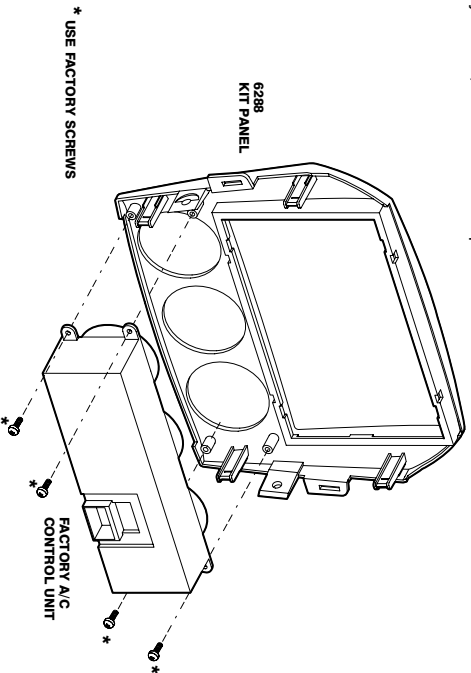

DIN MOUNT

1. Slide pocket into kit panel from front until it snaps into place.
2. Next, slide DIN sleeve into kit panel from front and bend tabs to hold into place.
3. Insert radio into sleeve until it snaps into place.

NOTE:
REAR SUPPORT AVAILABLE SEPARATELY. REAR SUPPORTING THE RADIO ADDS TO THE INSTALLATION'S STRUCTURAL INTEGRITY.

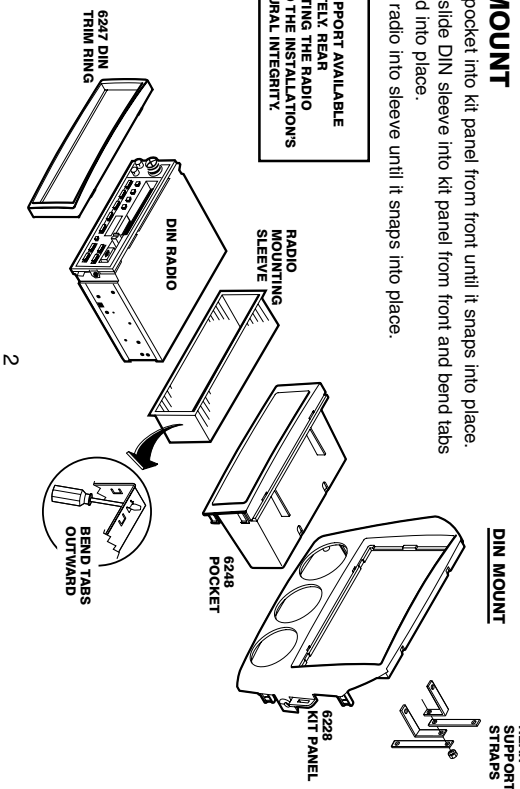

2

ISO MOUNT

1. Slide pocket into kit panel from front until it snaps into place.
2. Slide left and right brackets into their corresponding slots in kit panel.
3. Mount radio to brackets with radio supplied screws.
4. Snap trim ring into place.

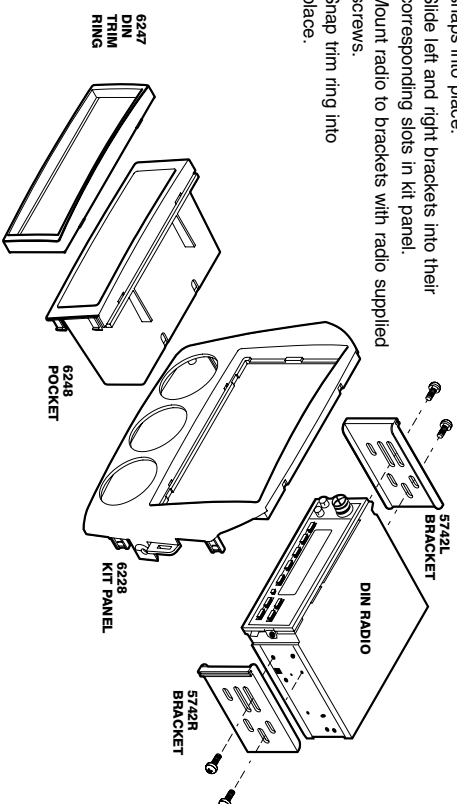

ISO MOUNT

DOUBLE DIN MOUNT

1. Slide left and right double DIN brackets into their corresponding slots in kit panel.
2. Mount radio to brackets with radio supplied screws.
3. Snap trim ring into place.

DOUBLE DIN ISO MOUNT

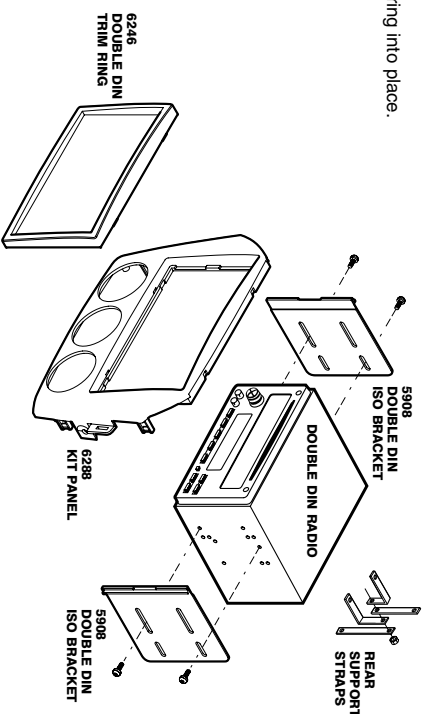

3