

## DASH DISASSEMBLY INSTRUCTIONS

1. Open the ashtray.
2. Carefully pry outward on the trim bezel from around the factory radio.
3. Depress the metal spring clip on each side of the Factory radio to release and pull the Radio forward.
4. Disconnect the wire harness and antenna lead and remove radio.

## KIT INSTALLATION INSTRUCTIONS

1. Using the (4) metal spring clips, insert (1) clip into each of the (4) sub-dash mounting hole locations. See illustration A below.
2. Mount radio to the installation kit and secure to the rear of the pocket.
3. Mount the kit using the (4) phillips screws supplied in this kit.
4. Insert (1) locator tab into recessed hole on back side of each mounting bracket on kit as shown in illustration B below.

**NOTE: 1996-1997 Locator tabs must be Downward**  
**1998-1999 Locator tabs must be Upward**

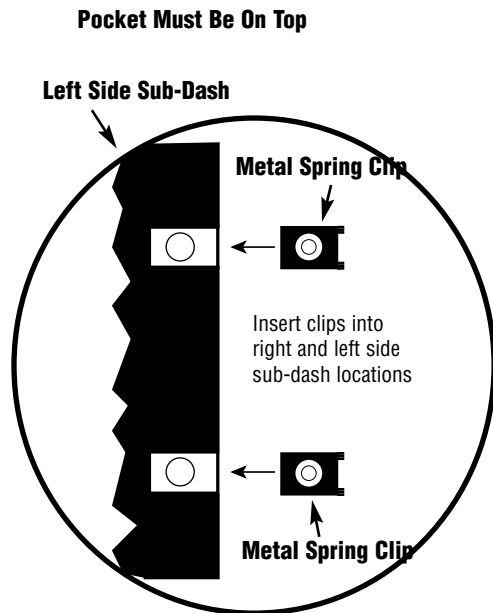

**Illustration A**

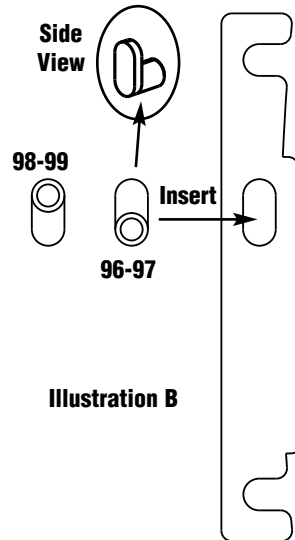

**Illustration B**



**American  
International**  
Car Stereo Installation Kits & Accessories

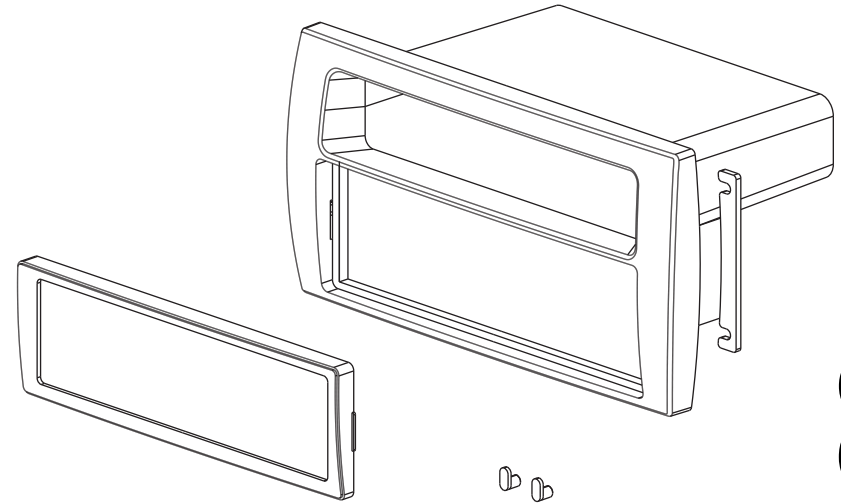

**GMK260 Mounting Kit**

## VEHICLE APPLICATIONS

**Cadillac**  
1996-99 DEVILLE ( With Colum Shift )

**Automotive Products Division**  
1040 Avenida Acaso • Camarillo, CA 93012, U.S.A.  
USA Sales (800) 336-6500  
Canada Sales (888) 922-3006 • USA Fax (805) 388-7950

**CUSTOMER HELP LINE**  
USA 800-323-4329 • Canada 800-245-8777

iGMK260