

KIT ASSEMBLY INSTRUCTIONS

Double DIN Applications

1. Remove the shaded tab from the bottom of each left and right mounting bracket
2. Attach the left and right side brackets to the main frame.
3. Cut and remove center rib from the main frame and file edges smooth.
4. Attach (1) ISO Spacer to the inside of upper section on both Left & Right mounting brackets as shown in Fig. D.
5. Insert ISO mountable radio between ISO mount brackets and loosely attach to sides of radio using screws provided with radio when possible or hardware included with kit.
6. Slide radio component forward or backward for desired look and tighten screws

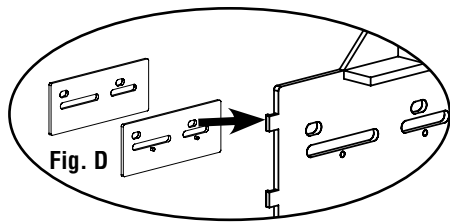

Attach (1) ISO Spacer to the inside of upper section on both Left & Right mounting brackets as shown in Fig. D.

Fig. E

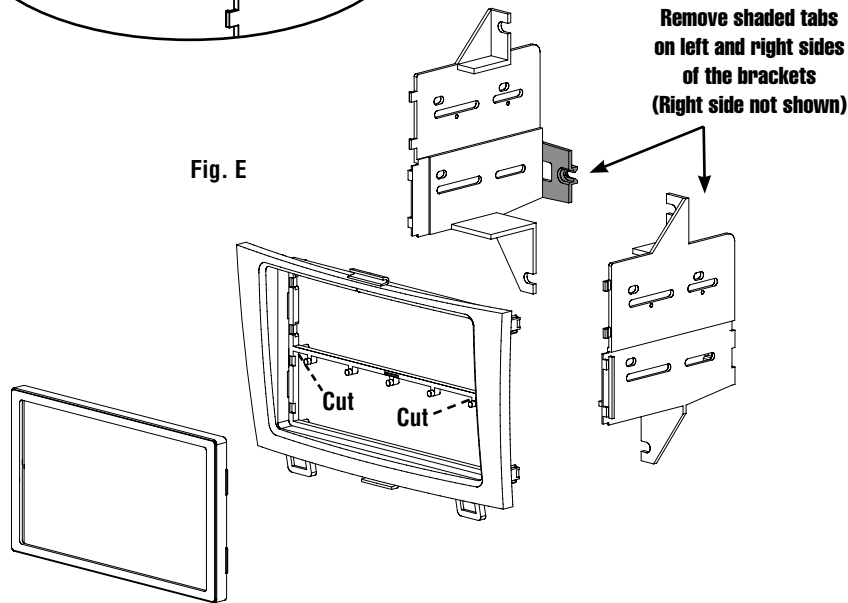

Remove shaded tabs on left and right sides of the brackets (Right side not shown)

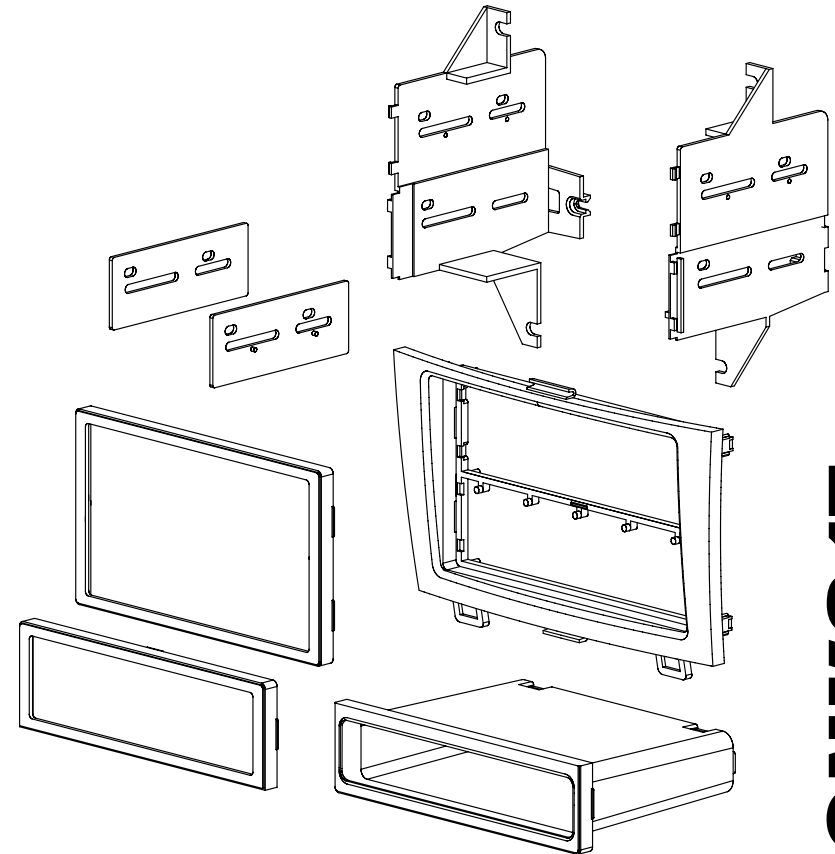

HONK817 Mounting Kit



www.aampglobal.com www.aius.net

2500 East Francis Street Ontario, CA 91761, U.S.A.

Sales: (800) 477-2267

Intl: (727) 572-9255

Support: 888-228-5560

VEHICLE APPLICATION

Honda

2007-11 CRV

DASH DISASSEMBLY & RADIO REMOVAL INSTRUCTIONS

1. Carefully remove the climate controls with a plastic removal tool.
2. Disconnect harnesses from climate controls, set aside.
3. Carefully lift up and remove the cover panel from the top of the dash behind the vent above the radio.
4. Carefully remove the vent assembly containing the hazard switch and passenger airbag light.
5. Disconnect harness and set aside.
6. Remove the (4) Phillips screws securing the radio in the dash.
7. Gently remove radio and disconnect all harnesses attached.

KIT ASSEMBLY INSTRUCTIONS

Single DIN Mounting Applications

1. Attach the left and right side brackets to the main bracket.
2. Insert pocket (part # POC817) into lower section of the main frame.
3. Attach left and right side brackets to the rear of the pocket using screws supplied.
4. Insert DIN sleeve from your new radio into the upper section of the installation kit.
5. Depress the tabs from inside the sleeves opening upward, outward, and downward to secure sleeve to the installation kit.

Note: ISO trim ring (ITR817) may be used in place of after-market radio's removable trim ring.

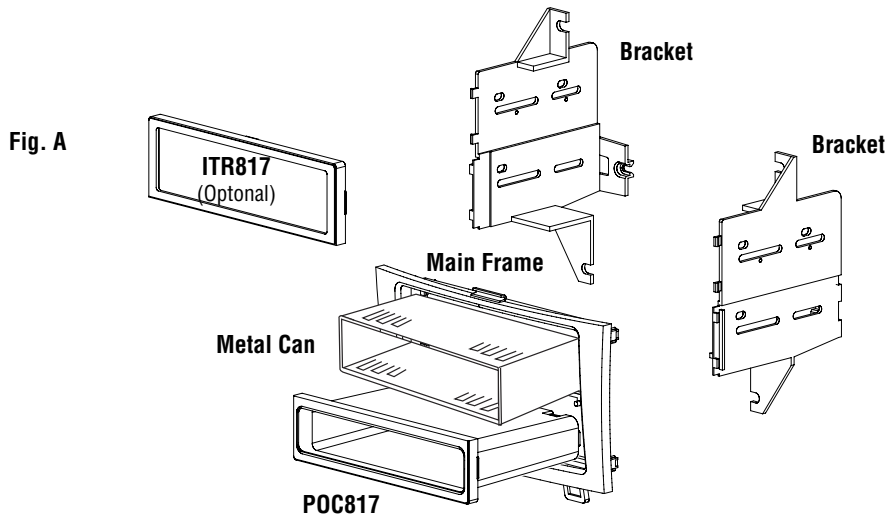

KIT ASSEMBLY INSTRUCTIONS

Single ISO Mounting Applications

1. Attach the left and right side brackets to the main bracket.
2. Insert pocket (part # POC-817) into lower section of the main frame.
3. Attach left and right side brackets to the rear of the pocket using screws supplied.
4. Attach (1) ISO Spacer to the inside of upper section on both Left & Right mounting brackets as shown in Fig. B.
5. Insert ISO mountable radio between ISO mount brackets and loosely attach to sides of radio using screws provided with radio when possible or hardware included with kit.
6. Slide radio component forward or backward for desired look and tighten screws.

Note: #1 - ISO trim ring (ITR-817) may be used in place of after-market radio's removable trim ring.
#2 - Spacers must read upright (This side up for single ISO install).

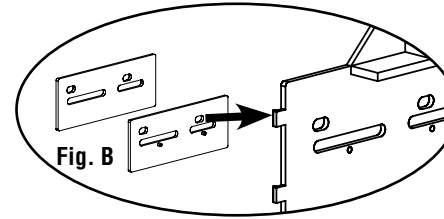

For ISO Mount Only: Attach (1) ISO Spacer to the inside of upper section (See note #2) on both Left & Right mounting brackets as shown in Fig. B.

