

2003-UP BMW X3

RADIO REMOVAL:

1. Using a panel removal tool, remove panel surrounding AC vents, disconnect and lift away.
2. Remove two (2) Phillips head screws from panel surrounding radio. Using panel removal tool, unsnap bottom portion of dash panel, disconnect and lift away.
3. Remove two (2) Phillips head screws from top radio mounting brackets, pull radio outward disconnect and left away.

MOUNTING THE RADIO

ISO DIN MOUNT: (DIN-E Radio with side mounting holes)

1. Bolt the right and left ISO mounting brackets to ISO DIN radio. Use hardware supplied with radio to bolt the mounting brackets.
2. Bolt assembled ISO DIN radio to factory dash. Mount to factory mounting hole position.
3. Bolt trim panel over assembled ISO DIN radio.

CAUTION:
REAR SUPPORT AVAILABLE SEPARATELY. REAR SUPPORTING THE RADIO ADDS TO THE INSTALLATIONS STRUCTURAL INTEGRITY.

VARIOUS REAR SUPPORTS (NOT INCLUDED)

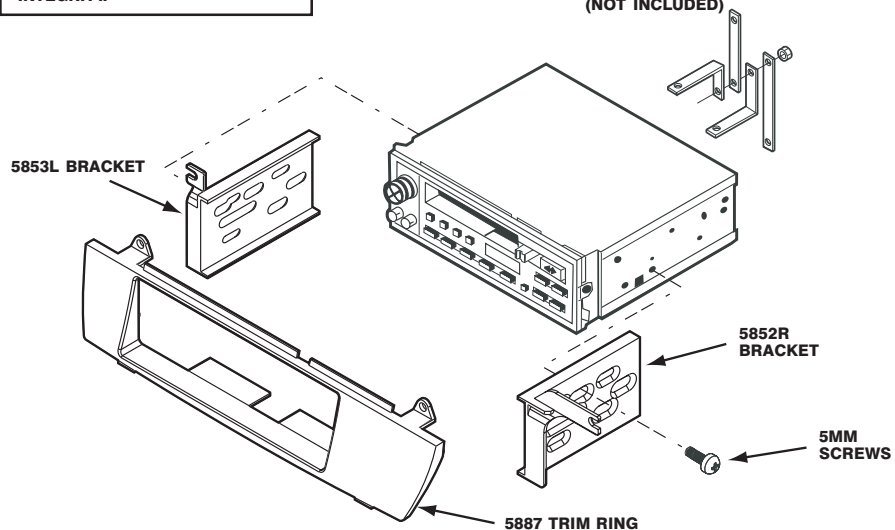

IN-DASH INSTALLATION KIT FOR 2004-UP BMW X3

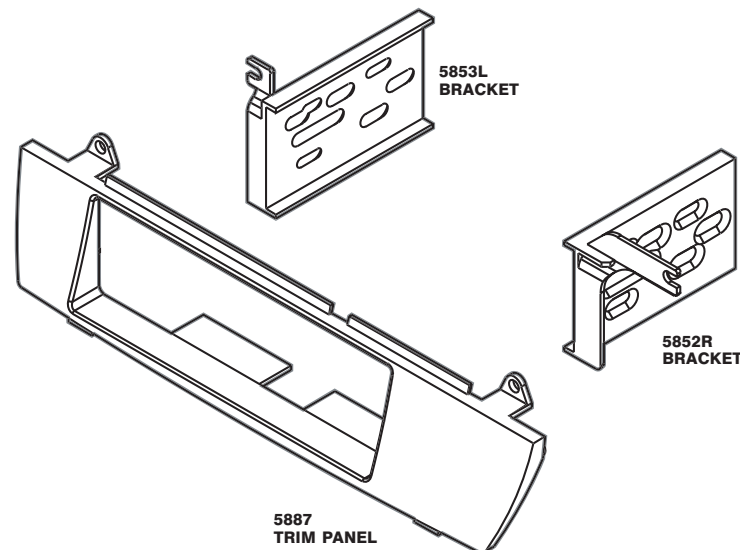

WIRE CODES

For Factory Wiring Codes go to: www.scosche-cars.com

INTRODUCTION

This premium installation kit is for the 2004-UP BMW X3 vehicles. Included are all the parts you need to mount your car stereo, cassette or CD player into your vehicle's dash. Refer to the individual instruction in this manual to remove your vehicle's factory radio and assemble the kit.

CAUTION:

Disconnect your vehicle's negative battery terminal before the installation to help prevent electrical damage. We recommend the use of a volt/ohm meter over a test light to check wiring. A test light or grounded wire probe can cause damage to the vehicle's computer and/or diagnostic systems. Avoid all factory air bag wiring - air bags can accidentally deploy causing serious injury or death.

NOTES:

- See your vehicle's instructions for any special tools your installation might require.
- Read all instructions accompanying your car stereo/cassette player for proper wiring and mounting instructions.

LIABILITY DISCLAIMER

This instruction booklet is based on carefully documented data and research of automobile dash disassembly, wire harness/codes and information pertaining to installation of this kit in the listed vehicles. Manufacturer cannot be held responsible for discrepancies/inconsistencies that may occur due to the automobile manufacturing changes or options, or damage that may occur in the automobile during the installation of components while using this booklet.

If you have any further questions call:

TECH HELP 1-800-621-3695x3

© 2005 SCOSCHE INDUSTRIES, INC.

BW2337 7/05 (3000005)