

**IN-DASH INSTALLATION KIT FOR
2007-UP KIA AMANTI**

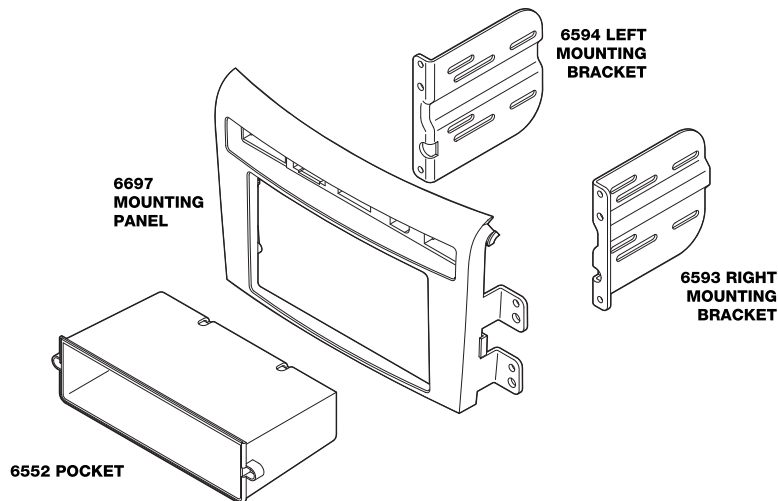

INTRODUCTION/PRELIMINARY

This premium installation kit is for 2007-Up Kia Amanti vehicles. Included are all the parts you need to mount your car stereo or CD player into your vehicle's dash. Refer to the individual instruction in this manual to remove your vehicle's factory radio and assemble the kit.

CAUTION
DISCONNECT YOUR VEHICLE'S NEGATIVE BATTERY TERMINAL BEFORE THE INSTALLATION TO HELP PREVENT ELECTRICAL DAMAGE. WE RECOMMEND THE USE OF A VOLT/OHM METER OVER A TEST LIGHT TO CHECK WIRING. A TEST LIGHT OR GROUNDED WIRE PROBE CAN CAUSE DAMAGE TO THE VEHICLE'S COMPUTER AND/OR DIAGNOSTIC SYSTEMS. AVOID ALL FACTORY AIRBAG WIRING - AIRBAGS CAN ACCIDENTALLY DEPLOY CAUSING SERIOUS INJURY OR DEATH.

- NOTES**
- See your vehicle's instructions for any special tools your installation might require.
 - Read all instructions accompanying your car stereo for proper wiring and mounting instructions.

FACTORY WIRING CODES

For Factory Wiring Codes go to: www.scosche-cars.com

CAR STEREO CONNECTORS		HY07B	HAAB
PROVIDE EASY CONNECTION OF YOUR CAR STEREO TO FACTORY WIRING HARNESS.			
HY07B 2005-Up Kia Sportage	HAAB 2005 -Up Honda Antenna Adapter		

LIABILITY DISCLAIMER

This instruction booklet is based on carefully documented data and research of automobile dash disassembly, wire harness/codes and information pertaining to installation of this kit (KA2095B) in 2007-Up Kia Amanti vehicles. Scosche Industries, Inc. cannot be held responsible for discrepancies/inconsistencies that may occur due to the automobile manufacturing changes or options, or damage that may occur in the automobile during the installation of components while using this booklet.

If you have any further questions, call our toll free technical help line at: **1-800-621-3695x3**

FACTORY STEREO REMOVAL

2007-UP KIA AMANTI

1. Unclip top of shifter knob (not silver trim).
2. Remove C-clip holding shift knob and pull up on shifter knob to remove.
3. Unclip and remove shifter surround.
4. With panel removal tool (PRT) unclip and remove cover panel at bottom of center console.
5. Extract (2) 10mm bolts at bottom of center console.
6. Unclip and remove cup holder and console trim panel (storage removes with panel).
7. Unclip and remove console rear panel (including ac vents and wood trim).
8. Extract (3) 10mm bolts from top of console at armrest hinge.
9. Extract (2) Phillips head screws from rear bottom of console.
10. Extract (4) Phillips head screws from front and center of top of console.
11. Unclip panels at front bottom of center console (panels do not need to be removed).
12. Lift center console and move back away from dash (console does not need to be removed).
13. Extract (2) Phillips head screws from bottom of stereo trim panels.
14. With PRT unclip and remove stereo trim panels.
15. Extract (4) Phillips head screws securing stereo.
16. Unplug stereo and seat warmer/hazard buttons and remove stereo.

MOUNTING THE STEREO

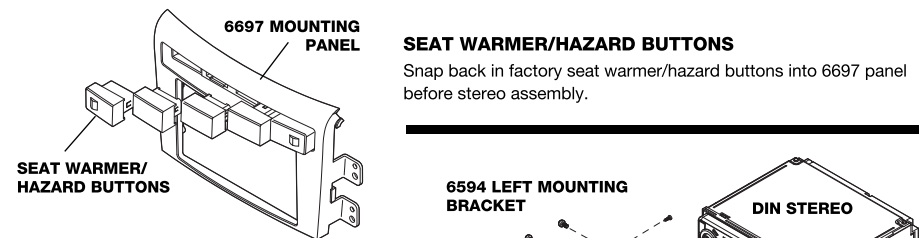

SEAT WARMER/HAZARD BUTTONS

Snap back in factory seat warmer/hazard buttons into 6697 panel before stereo assembly.

SINGLE DIN MOUNT

1. Attach the 6552 pocket to 6697 panel using (2) screws supplied.
2. Attach the 6593 and 6594 brackets to 6697 panel using (4) screws supplied.
3. Align and screw aftermarket stereo to 6593 and 6654 brackets using screws supplied with aftermarket stereo.
Note: If hardware is not supplied with aftermarket stereo use hardware from factory stereo.
4. Reconnect stereo and factory seat warmer/hazard buttons.
5. Screw and secure stereo kit assembly to dash using the removed (4) Phillips head screws.
6. Finish dash reassembly.

DOUBLE DIN MOUNT

1. Attach the 6593 and 6594 brackets to 6697 panel using (4) screws supplied.
2. Align and screw aftermarket double din stereo to 6593 and 6594 brackets using screws supplied with aftermarket stereo.
Note: If hardware is not supplied with aftermarket stereo use hardware from factory stereo.
3. Reconnect stereo and factory seat warmer/hazard buttons.
4. Screw and secure stereo kit assembly to dash using the removed (4) Phillips head screws.
5. Finish dash reassembly.

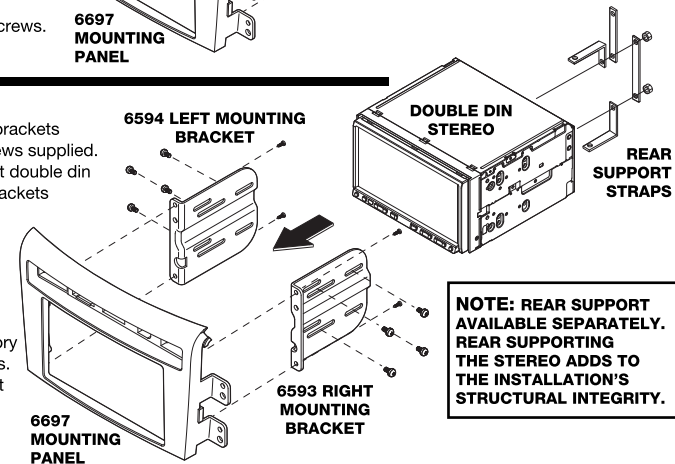

NOTE: REAR SUPPORT AVAILABLE SEPARATELY. REAR SUPPORTING THE STEREO ADDS TO THE INSTALLATION'S STRUCTURAL INTEGRITY.