

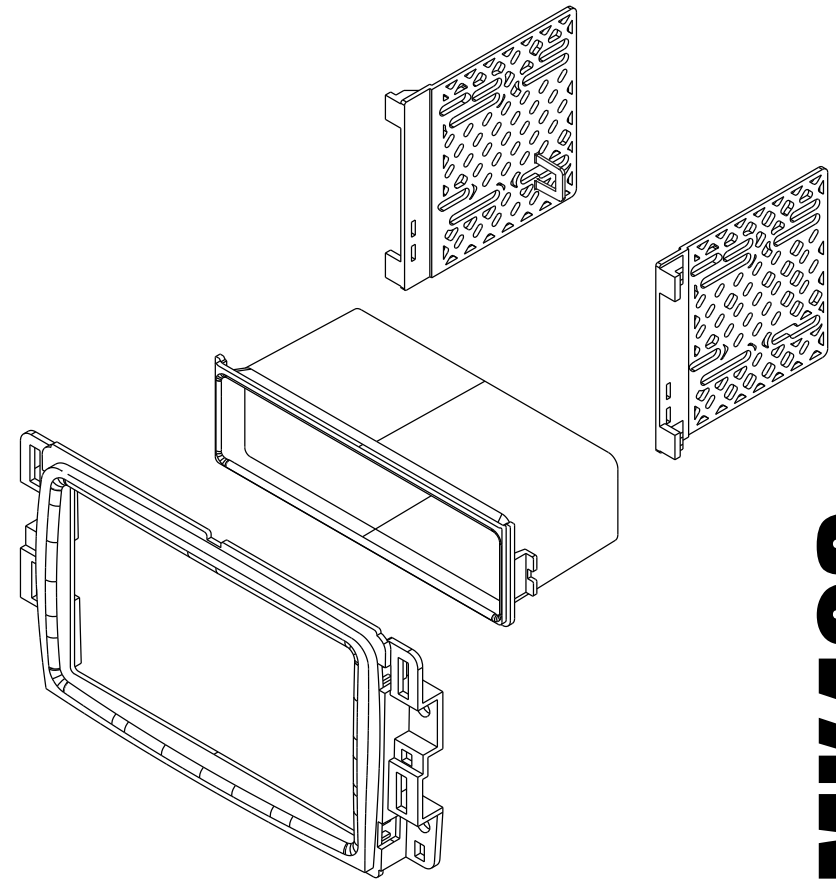

**American
International**
Car Stereo Installation Kits & Accessories



GMK403 Mounting Kit

WWW.AIUS.NET
2500 East Francis Street Ontario, CA 91761, U.S.A.
USA Sales (800) 336-6500
Canada Sales (888) 922-3006

VEHICLE APPLICATION

Buick
2013-16 ENCLAVE
Chevrolet
2013-16 TRAVERSE
GMC
2013-16 ACADIA

CUSTOMER HELP LINE
USA 800-323-4329 • Canada 800-245-8777

iGMK403

DASH DISASSEMBLY INSTRUCTIONS

1. Carefully unclip the dash trim bezel from around the radio (see photo below), disconnect the climate control harness and remove trim bezel.
2. Remove the (4) Phillips screws securing the radio/hazard button assembly to the sub-dash.
3. Pull radio forward, disconnect the wire harness(s) and antenna lead and remove radio/hazard button assembly.
4. There is no need to unplug and remove the hazard button assembly, just set aside carefully.



SINGLE ISO w/POCKET INSTALLATION INSTRUCTIONS

1. Insert ISO brackets to rear of kit as shown in Figure A
2. Insert pocket into lower section of kit from rear & lock into slots of mounting brackets.
3. Insert ISO mountable radio between ISO mount brackets and loosely attach to sides of radio using screws provided with radio when possible or screws supplied with kit.
4. Slide radio forward or backward for desired look and tighten screws.
5. Attach a rear support bracket to the rear of the new radio and adjust as necessary to support the weight of the radio (Optional)

Fig A

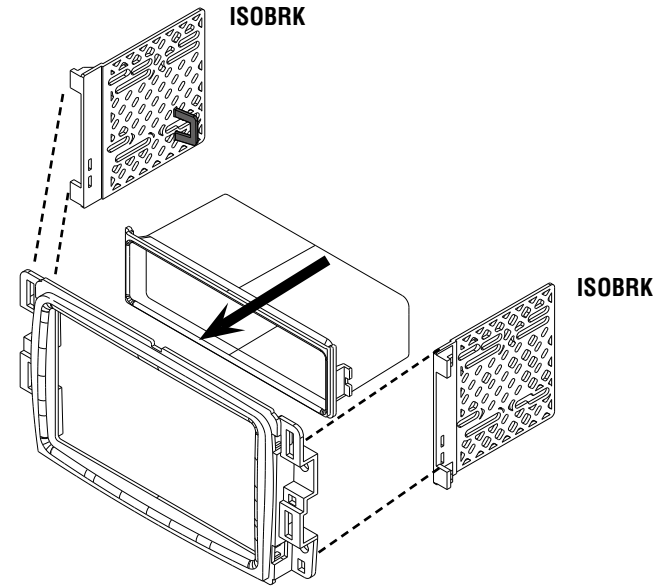

DOUBLE DIN INSTALLATION INSTRUCTIONS

1. Attach ISO brackets to the rear of the main mounting kit.
2. Slide radio into kit from rear & attach to ISO mounting brackets using screws supplied with radio when possible or screws supplied with kit (do not tighten screws at this time).
3. Slide radio forward or backward for your desired look and then tighten the mounting screws.
4. Suggested...Attach rear support.

Fig B

