

2000-UP MAZDA MPV KIT

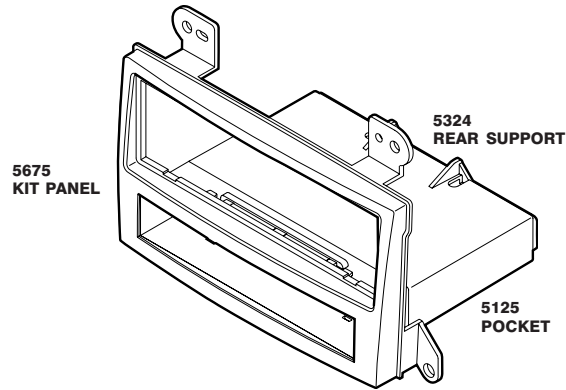

INTRODUCTION / PRELIMINARY

Thank you for purchasing the Scosche MA1539B Kit. This kit was manufactured with the highest of quality standards.

NOTES:

- See your vehicle's instructions for any special tools your installation might require.
- Read all instructions accompanying your car stereo/cassette player for proper wiring and mounting instructions.

WIRE CODES

For Factory Wiring Codes go to: www.scosche-cars.com, or call

RADIO REMOVAL

1. Remove two (2) Phillips Head Screws from instrument cluster. Remove entire panel surrounding radio, A/C and instrument cluster.
2. Remove four (4) Phillips Head Screws securing radio to the dash. Disconnect and remove.

MOUNTING THE RADIO

DIN RADIO INSTALLATION (DETACHABLE FACE/PULLOUT)

Slide the mounting sleeve (metal shroud) into the panel's radio opening and bend all available mounting tabs outward (see inset). Slide the radio into the mounting sleeve once it has been fastened to the kit panel until the radio locks into place.

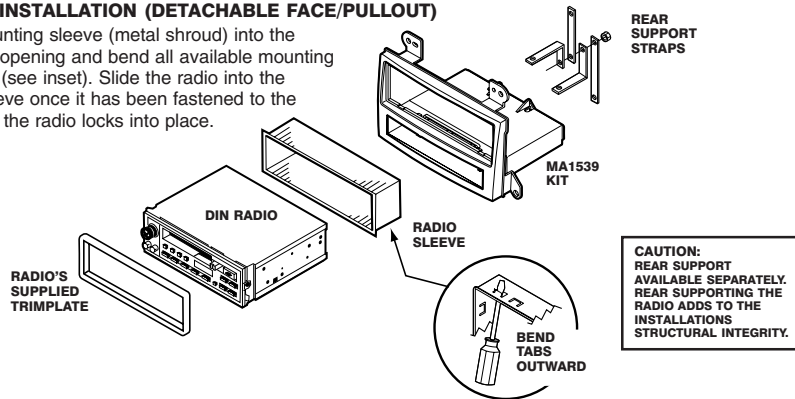

LIABILITY DISCLAIMER

This instruction booklet is based on carefully documented data and research of automobile dash disassembly, wire harness/codes and information pertaining to installation of this kit in the listed vehicles. Manufacturer cannot be held responsible for discrepancies/inconsistencies that may occur due to the automobile manufacturing changes or options, or damage that may occur in the automobile during the installation of components while using this booklet.

If you have any further questions call:

TECH HELP 1-800-621-3695x3

© 2004 SCOSCHE INDUSTRIES, INC.

SI 7/04 - MA1539B (3000003)

2000-UP MAZDA MPV KIT

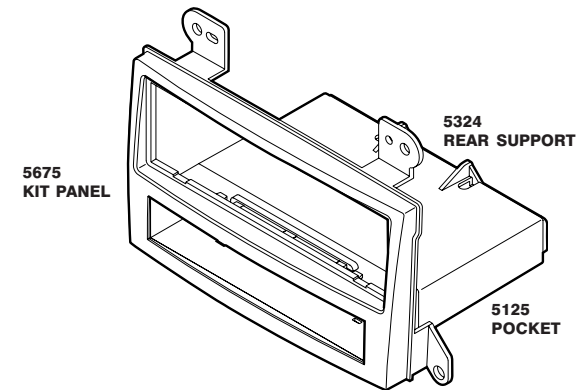

INTRODUCTION / PRELIMINARY

Thank you for purchasing the Scosche MA1539B Kit. This kit was manufactured with the highest of quality standards.

NOTES:

- See your vehicle's instructions for any special tools your installation might require.
- Read all instructions accompanying your car stereo/cassette player for proper wiring and mounting instructions.

WIRE CODES

For Factory Wiring Codes go to: www.scosche-cars.com, or call

RADIO REMOVAL

1. Remove two (2) Phillips Head Screws from instrument cluster. Remove entire panel surrounding radio, A/C and instrument cluster.
2. Remove four (4) Phillips Head Screws securing radio to the dash. Disconnect and remove.

MOUNTING THE RADIO

DIN RADIO INSTALLATION (DETACHABLE FACE/PULLOUT)

Slide the mounting sleeve (metal shroud) into the panel's radio opening and bend all available mounting tabs outward (see inset). Slide the radio into the mounting sleeve once it has been fastened to the kit panel until the radio locks into place.

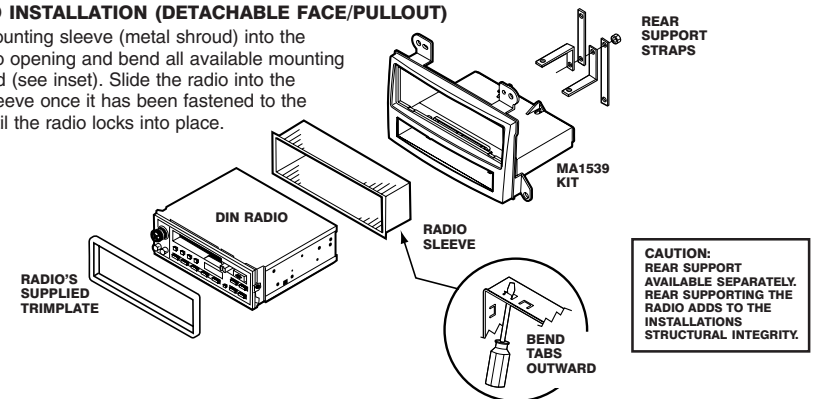

LIABILITY DISCLAIMER

This instruction booklet is based on carefully documented data and research of automobile dash disassembly, wire harness/codes and information pertaining to installation of this kit in the listed vehicles. Manufacturer cannot be held responsible for discrepancies/inconsistencies that may occur due to the automobile manufacturing changes or options, or damage that may occur in the automobile during the installation of components while using this booklet.

If you have any further questions call:

TECH HELP 1-800-621-3695x3

© 2004 SCOSCHE INDUSTRIES, INC.

SI 7/04 - MA1539B (3000003)