

For information about other American International automotive accessories visit our website at:

<http://www.aius.net>

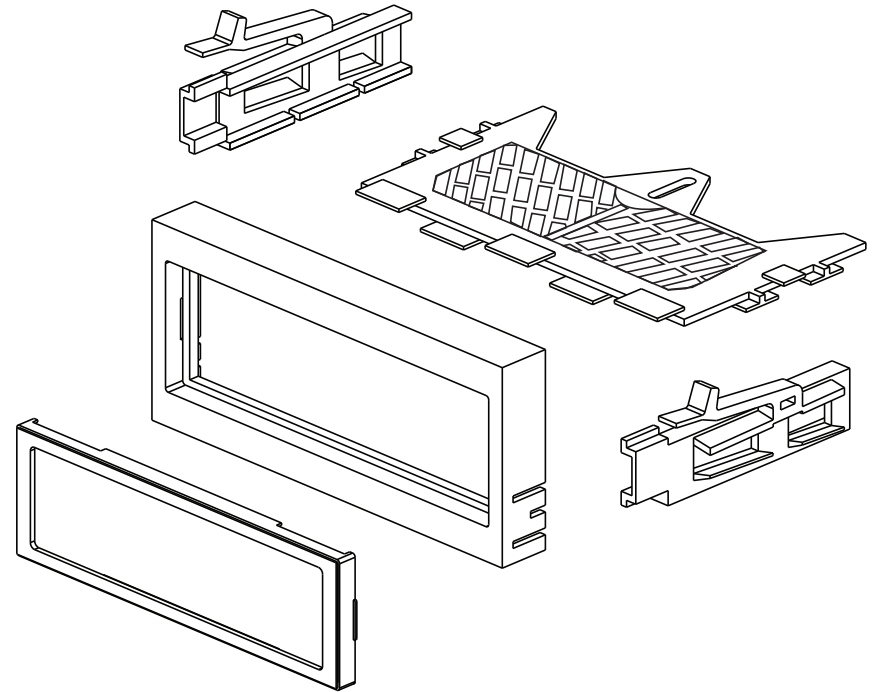

**American
International**
Car Stereo Installation Kits & Accessories



GMK345 Mounting Kit



American International

WWW.AIUS.NET

2500 East Francis Street Ontario, CA 91761, U.S.A.

USA Sales (800) 336-6500

Canada Sales (888) 922-3006

CUSTOMER HELP LINE

USA 800-323-4329 • Canada 800-245-8777

iGMK345

VEHICLE APPLICATIONS

Cadillac

1999-02 ESCALADE/EXT

Chevrolet

1996-05 ASTRO VAN

2002 AVALANCHE

1996-00 EXPRESS VAN

1995-02 FULL SIZE PICKUPS

SILVERADO

1995-02 SUBURBAN

1995-02 TAHOE

GMC

1995-02 FULL SIZE PICKUPS

SIERRA

1996-05 SAFARI VAN

1996-00 SAVANA VAN

1995-99 SUBURBAN

1995-02 YUKON/DENALI

2000-02 YUKON XL DENALI

DASHBOARD DISASSEMBLY

CADILLAC – 1999-2002 ESCALADE / EXT

CHEVROLET – 2002 AVALANCHE & 1995-2002 FULL SIZE PICKUP /SUBURBAN /TAHOE

GMC–1995-2002 SIERRA /SUBURBAN &1995-1999 YUKON DENALI & 2001-2002 YUKON XL/DENALI

1. Tilt the steering wheel to its lowest position.
2. Engage the parking brake.
3. Insert the ignition key into the ignition switch, and then turn the ignition switch to the ON position. Do not start the engine! (Not required for manual shift vehicles).
4. Depress the brake pedal and adjust the shift lever to the lowest gear position (not required for manual shift vehicles).
5. Carefully unclip the radio / climate control trim bezel by pulling it forward, (towards yourself) then disconnect all wire harnesses attached to the rear of the trim bezel and lift the radio / climate control trim bezel upward to remove it from the dashboard.
6. Depress the retaining clips securing the radio to the sub-dash and then pull the radio forward, unplug the harness(s) and antenna lead and remove radio.

1996-2000 – CHEVROLET – EXPRESS VAN & 1996-2000 – GMC – SAVANA VAN

1. Carefully unclip and remove the trim panel below the steering column.
2. Carefully unclip the radio / climate control dash bezel and pull the bezel forward, unplug any factory harness attached to the rear panel and remove the panel.
3. Depress the retaining clips securing the radio to the sub-dash and then pull the radio forward, unplug the harness(s) and antenna lead and remove radio.

1996-2005 – CHEVROLET – ASTRO VAN & 1996-2005 – GMC – SAFARI VAN

1. Tilt the steering wheel to its lowest position.
2. Engage the parking brake.
3. Insert the ignition key into the ignition switch, and then turn the ignition switch to the ON position. Do not start the engine! (Not required for manual shift vehicles)
4. Depress the brake pedal and adjust the shift lever to the lowest gear position. (Not required for manual shift vehicles)
5. Carefully unclip the radio / climate control / instrument bezel from the sub- dash.
6. Unplug any switch or wiring harness connected to the dash bezel.
7. Starting with the top of the bezel, roll the bezel forward, (towards you), then upward to remove it from the sub-dash.
8. Depress the retaining clips securing the radio to the sub-dash and then pull the radio forward, unplug the harness(s) and antenna lead and remove radio.

GMP345 (Sold Separately)

VEHICLE APPLICATION

Chevy/GMC

- 1995-02 FULL SIZE PU's
- 1995-02 SUV's
- 1996-05 ASTRO VAN
- 1996-05 SAFARI VAN

Cadillac

- 1999-00 ESCALADE

FEATURES

- OEM style replacement pocket.
- Fits full size trucks and SUVs.
- Replaces separate CD or cassette slave unit.
- E-Z to Install, locks securely into subdash.

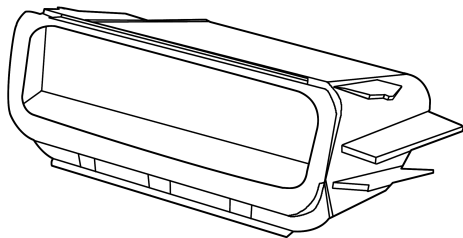

KIT ASSEMBLY

1. Insert left and right brackets into face plate as shown below.
2. Insert rear support tray between the left and right brackets and bottom edge of face plate.

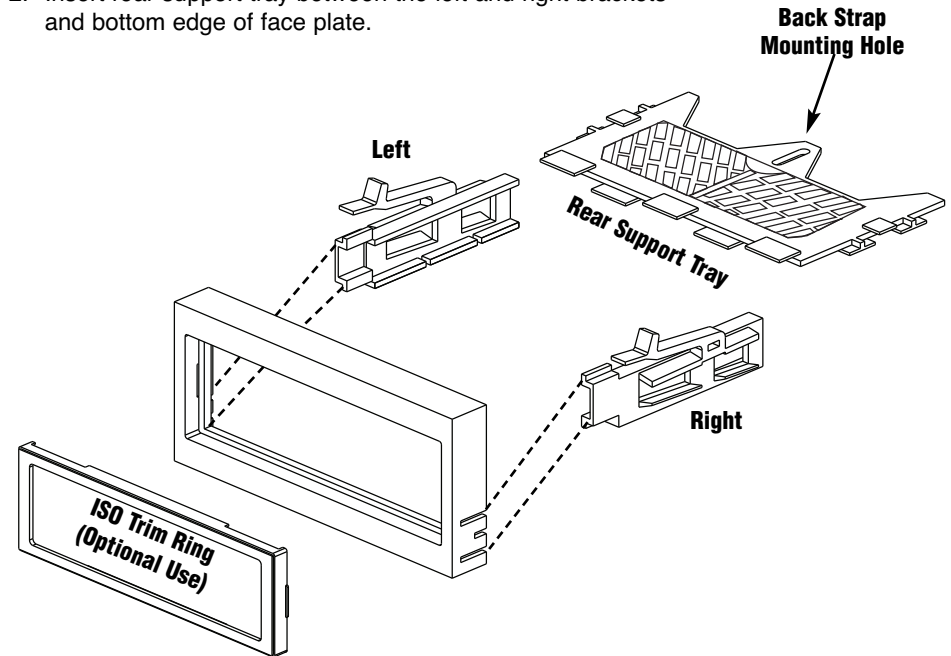

FOR DIN MOUNT APPLICATIONS

Insert DIN sleeve from your new radio into the radio opening of the installation kit and depress the tabs on the front edge of the sleeve to secure sleeve to kit.

1. For rear support attach a back strap to the rear of the radio and secure to back strap mounting hole on rear support tray.

