

DASH DISASSEMBLY INSTRUCTIONS

1. Carefully unclip the dash trim bezel from around the radio, disconnect the clock harness and remove trim bezel.
2. Remove the (4) Phillips screws securing the radio to the sub-dash.
3. Remove the (2) Phillips screws securing the lower pocket to the sub-dash.
4. Remove the (2) Phillips screws securing the Climate controls to the sub-dash.
5. Carefully pull the lower pocket and Climate controls slightly outward to allow the radio to be pulled out.
6. Pull radio forward, disconnect the wire harness(s) and antenna lead and remove radio.

RADIO INSTALLATION INSTRUCTIONS

1. Insert DIN sleeve from your new radio into the radio opening of the installation kit.
2. Depress the tabs from inside the sleeves opening upward, outward, and downward to secure sleeve to the installation kit.

ISO MOUNT INSTALLATION INSTRUCTIONS

INSERT ISO MOUNT BRACKETS AS SHOWN AND ATTACH TO THE LEFT SIDE AND RIGHT SIDE OF MAIN BRACKET (#GM-K394) ONLY WHEN ISO MOUNTING RADIO.

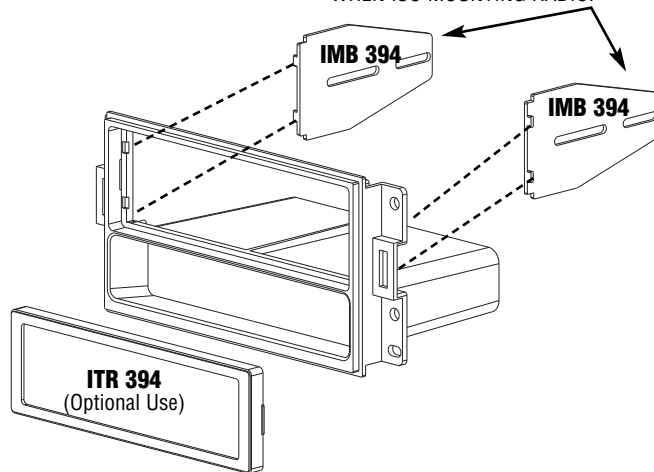

American International

WWW.AIUS.NET

2500 East Francis Street Ontario, CA 91761, U.S.A.

USA Sales (800) 336-6500

Canada Sales (888) 922-3006

CUSTOMER HELP LINE

USA 800-323-4329 • Canada 800-245-8777



**American
International**
Car Stereo Installation Kits & Accessories

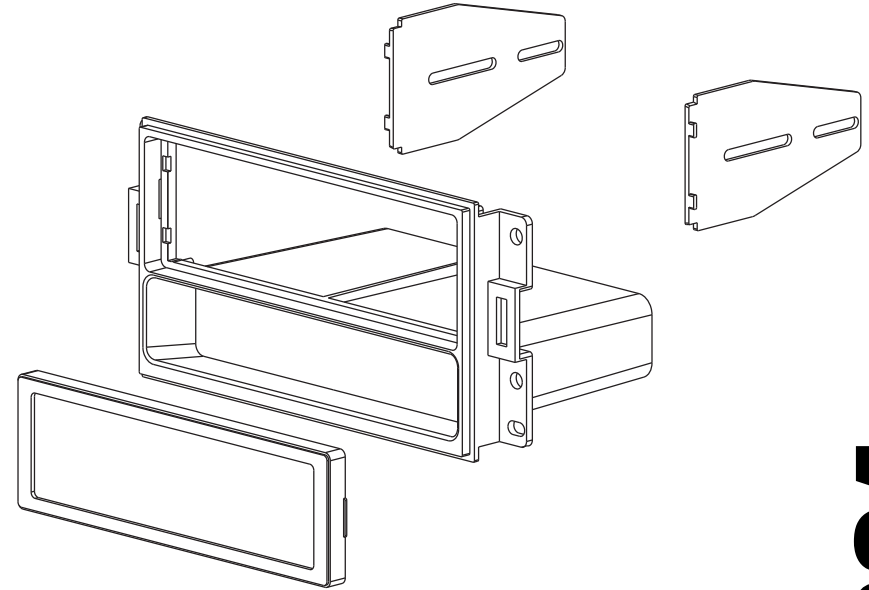

GMK394 Mounting Kit

VEHICLE APPLICATIONS

Pontiac
2004-08 GRAND PRIX